

TM11-6625-3077-14

TECHNICAL MANUAL

**OPERATOR'S, ORGANIZATIONAL,
DIRECT SUPPORT,
AND
GENERAL SUPPORT MAINTENANCE MANUAL**

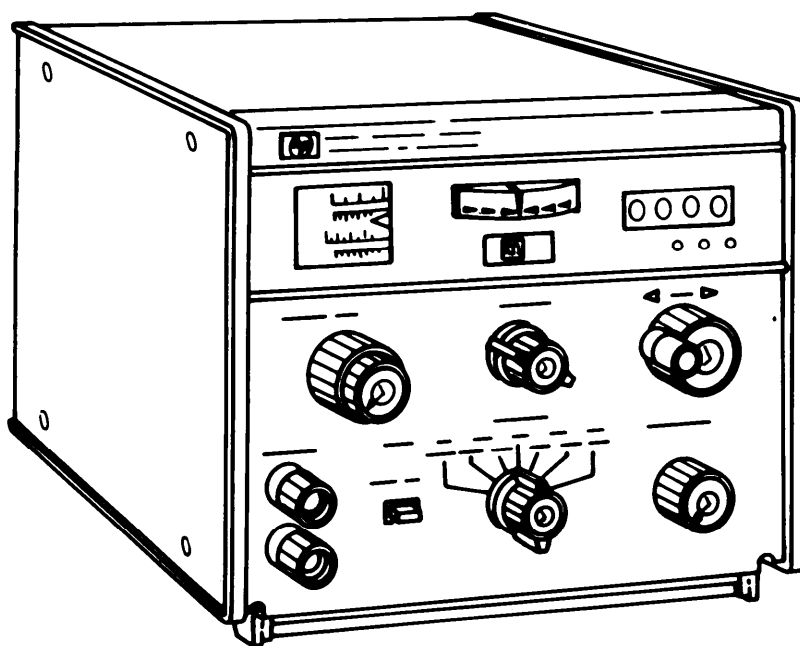

IMPEDANCE BRIDGE

ZM-71A/U

(NSN 6625-00-236-1536)

HEADQUARTERS, DEPARTMENT OF THE ARMY

JUNE 1984

**TABLE OF
CONTENTS**

**GENERAL
INFORMATION**

**EQUIPMENT
DESCRIPTION**

**OPERATOR'S
CONTROLS**

**OPERATOR'S/ORGANIZATIONAL
PREVENTIVE MAINTENANCE
CHECKS AND SERVICES**

**OPERATING
INSTRUCTIONS**

**OPERATOR'S/ORGANIZATIONAL
TROUBLESHOOTING
PROCEDURES**

**OPERATOR'S/ORGANIZATIONAL
MAINTENANCE
PROCEDURES**

**GENERAL SUPPORT
MAINTENANCE**

**SUBJECT
INDEX**



5

SAFETY STEPS TO FOLLOW IF SOMEONE IS THE VICTIM OF ELECTRICAL SHOCK

1

DO NOT TRY TO PULL OR GRAB THE INDIVIDUAL

2

IF POSSIBLE TURN OFF THE ELECTRICAL POWER

3

IF YOU CANNOT TURN OFF THE ELECTRICAL POWER, PULL, PUSH, OR LIFT THE PERSON TO SAFETY USING A WOODEN POLE OR A ROPE OR SOME OTHER INSULATING MATERIAL

4

SEND FOR HELP AS SOON AS POSSIBLE

5

AFTER THE INJURED PERSON IS FREE OF CONTACT WITH THE SOURCE OF ELECTRICAL SHOCK, MOVE THE PERSON A SHORT DISTANCE AWAY AND IMMEDIATELY START ARTIFICIAL RESUSCITATION

WARNING

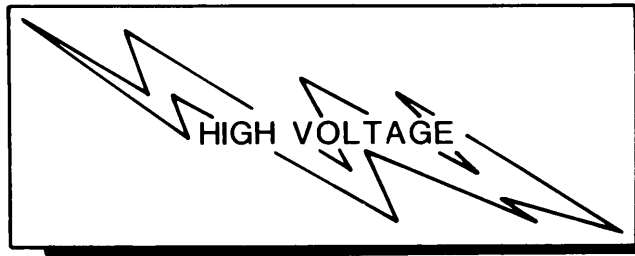

is used in the operation of this equipment

DEATH ON CONTACT

may result if personnel fail to observe safety precautions

Never perform maintenance on electronic equipment unless there is another person nearby who is familiar with the operation and hazards of the equipment and who is competent in administering first aid. When the technician is aided by operators, he must warn them about dangerous areas.

Whenever possible, the power supply to the equipment must be shut off before beginning maintenance on the equipment. Take particular care to ground every capacitor likely to hold a dangerous potential. When working inside the equipment, after the power has been turned off, always ground every part before touching it.

Be careful not to contact high-voltage connections of 115 V ac input when installing or operating the equipment.

Whenever the nature of the operation permits, keep one hand away from the equipment to reduce the hazard of current flowing through vital organs of the body.

WARNING Do not be misled by the term "LOW VOLTAGE". Potentials as low as 50 volts may cause death under adverse conditions.

HOW TO USE THIS MANUAL

This manual tells you about your Impedance Bridge ZM-71A/U and contains instructions about how to use it during maintenance on other electronic equipment.

The technical manual for the electronic equipment you are maintaining will tell you where to make certain connections and when to use various accessories which are part of the ZM-71A/U.

When you first receive your ZM-71A/U, start at the front of the manual and go all the way through to the back. Become familiar with every part of the manual and the ZM-71A/U.

This manual has an edge index which will help you find specific information in a hurry. Simply spread the pages on the right edge of the manual until the printed blocks can be seen. Open the manual where the block on the edge of the page lines up with your selected topic printed on the front cover block.

Technical Manual

No. 11-6625-3077-14

HEADQUARTERS
DEPARTMENT OF THE ARMY
Washington, D.C., 8 June, 1984

**OPERATOR'S, ORGANIZATIONAL, DIRECT SUPPORT
AND GENERAL SUPPORT MAINTENANCE MANUAL**

FOR

IMPEDANCE BRIDGE

ZM-71A/U

(NSN 6625-00-236-1536)

REPORTING ERRORS AND RECOMMENDING IMPROVEMENTS

You can help improve this manual. If you find any mistakes or if you know of a way to improve the procedures, please let us know. Mail your letter, DA Form 2028, (Recommended Changes to Publications and Blank Forms), or DA Form 2028-2 (located in the back of this manual) direct to: Commander, US Army Communications-Electronics Command and Fort Monmouth, ATTN: DRSEL-ME-PCF, Fort Monmouth, New Jersey 07703.

A reply will be furnished to you.

TABLE OF CONTENTS

		Page
		C
	HOW TO USE THIS MANUAL	C
CHAPTER	1. INTRODUCTION	1-1
Section	I. General Information	1-1
	II. Equipment Description	1-4
	Equipment Characteristics, Capabilities, and features	1-4
	Location and Description of Major Components	1-5
CHAPTER	2. OPERATING INSTRUCTIONS	2-1
Section	I. Description and Use of Operators Controls and Indicators	2-1
	II. Preventive Maintenance Checks and Services	2-7
	III. Operation Under Usual Conditions	2-12
	IV. Operation Under Unusual Conditions	2-26
CHAPTER	3. MAINTENANCE INSTRUCTIONS	3-1
Section	I. Lubrication Instructions	3-1
	II. Troubleshooting Procedures	3-1
	III. Maintenance Procedures	3-6
CHAPTER	4. DIRECT AND GENERAL SUPPORT MAINTENANCE	4-1
Section	I. Repair Parts, Special Tools, TMDE, and Support Equipment	4-1
	II. Service Upon Receipt	4-1
	III. Principles of Operation	4-2
	IV. Preventive Maintenance Checks and Services	4-12
	V. Troubleshooting Procedures	4-17
	VI. Maintenance Procedures	4-28
	VII. Preparation for Storage and Shipment	4-58
APPENDIX	A. REFERENCES	A-1
	B. MAINTENANCE ALLOCATION	B-1
	C. COMPONENTS OF END ITEM AND BASIC ISSUE ITEMS	C-1
	SUBJECT INDEX.	I-1

LIST OF ILLUSTRATIONS

Illus figure	Title	Page
1-1	Impedance Bridge ZM-71A/U, front view	1-1
1-2	Location and Description of Major Components	1-5
2-1	Description and use of operator controls and Indicators, front view	2-1
2-2	Description and Use of Operator Controls and Indicators, rear view.	2-5
4-1	Bridge Circuit Configuration	4-3
4-2	Impedance Bridge Wiring Diagram	4-29
	Impedance Bridge Block Diagram	FO-1
	Range and Function Switch Schematic Diagram	FO-2
	Power Supply and 1KHz Oscillator Schematic Diagram	FO-3
	Reference Voltage Schematic Diagram	FO-4
	Detector Schematic Diagram	FO-5

All foldouts are located in back of this book.

LIST OF TABLES

Table number	Title	Page
1-1	Equipment Data	1-6
2-1	Operator PMCS	2-9
3-1	Operator Troubleshooting	3-1
4-1	General Support PMCS	4-13
4-2	Operating Procedure to Troubleshooting Table Cross-reference	4-18
4-3	General Support Troubleshooting Procedures	4-19
4-4	Impedance Bridge Wire List	4-31

CHAPTER 1

INTRODUCTION

SECTION I. GENERAL INFORMATION

1-1. SCOPE.

This manual describes Impedance Bridge ZM-71A/U (fig. 1-1) and provides operation and maintenance instructions. The ZM-71A/U is designed to make fast, easy measurements of resistance (R), capacitance (C), inductance (L), capacitor dissipation factor (D), or inductance quality factor (Q).

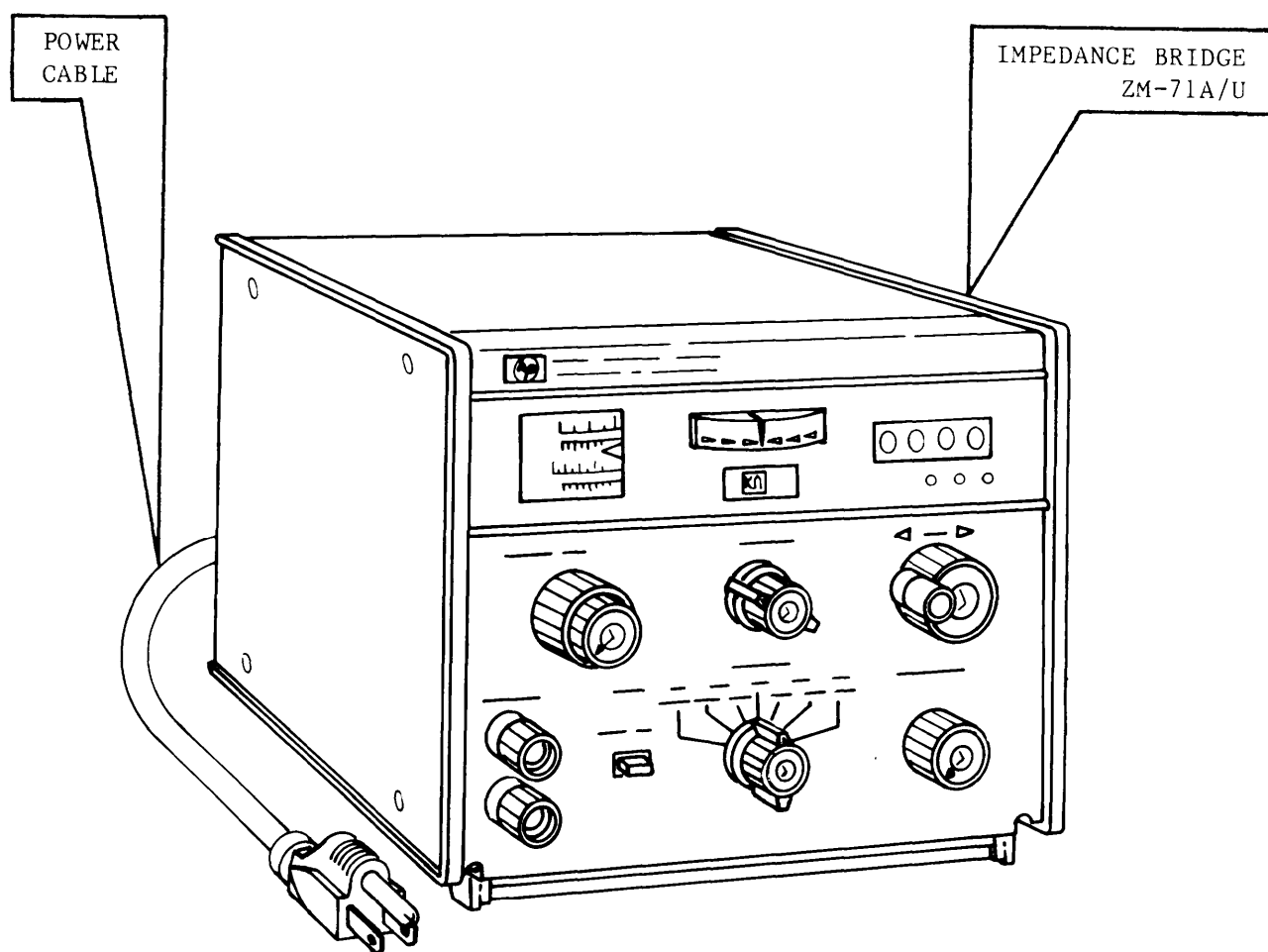

Figure 1-1. Impedance Bridge ZM-71A/U, front view.

1-2. CONSOLIDATED INDEX OF ARMY PUBLICATIONS AND BLANK FORMS.

Refer to the latest issue of DA Pam 310-1 to determine whether there are new editions, changes, or additional publications pertaining to the equipment.

1-3. MAINTENANCE FORMS, RECORDS AND REPORTS.

a. Report of Maintenance and Unsatisfactory Equipment. Department of the Army forms and procedures used for equipment maintenance will be those prescribed by DA Pam 738-750 as contained in Maintenance Management Update.

b. Report of Packaging and Handling Deficiencies. Fill out and forward SF 364 (Report of Discrepancy) (ROD) as prescribed in AR 735-11-2/DLAR 4140.55/NAVMATINST 4355.73A/AFR 400-54/MCO 4430.3F.

c. Discrepancy in Shipment Report (DISREP) (SF 361). Fill out and forward Discrepancy in Shipment Report (DISREP) (SF 361) as prescribed in AR 55-38/NAVSUPINST 4610.33C/AFR 75-18/MCO P4610.19D/DLAR 4500.15.

1-4. ADMINISTRATIVE STORAGE.

Refer to TM 740-90-1 for administrative storage procedures.

1-5. DESTRUCTION OF ARMY ELECTRONICS MATERIEL.

Destruction of army electronics material to prevent enemy use shall be in accordance with TM 750-244-2.

1-6. REPORTING EQUIPMENT IMPROVEMENT RECOMMENDATIONS (EIR).

If your ZM-71A/U needs improvement, let us know. Send us an EIR. You, the user, are the only one who can tell us what you don't like about your equipment. Let us know why you don't like the design or performance. Put it on an SF 368 (Quality Deficiency Report (SF 368)). Mail it to us at Commander , US Army Communications-Electronics Command, and Fort Monmouth, ATTN: DRSEL-ME-MP, Fort Monmouth NJ 07703. We'll send you a reply.

1-7. WARRANTY INFORMATION.

The ZM-71A/U is warranted by Hewlett-Packard Company for one year. Report all defects in material or workmanship to your supervisor who will take appropriate action through your organizational maintenance shop. It starts on the date, found in block 23, DA form 2408-9, in the log book.

1-8. LIST OF ABBREVIATIONS.

AR is Army Regulation
C is capacitance
D is capacitor dissipation factor
DA is Department of the Army
F is farads
H is henrys
I is inductance
K is Kilo (+3)
mV is millivolts

1-8. LIST OF ABBREVIATIONS (CONTINUED).

M is Meg (+6)
m is mills (-3)
n is Nano (-9)
p is Pica (-12)
Pam is pamphlet
para is paragraph
Q is inductor quality factor
R is resistance
SF is standard form
u is micro (-6)
V is volts
W is watts

1-9. PREPARATION FOR STORAGE OR SHIPMENT.

See paragraph 4-34.

SECTION II. EQUIPMENT DESCRIPTION

1-10. EQUIPMENT CHARACTERISTICS, CAPABILITIES, AND FEATURES.

IMPEDANCE BRIDGE

The ZM-71A/U is designed to make quick and easy measurements of resistance (R), inductance (L), capacitance (C), capacitor dissipation factor (D), and inductance quality factor (Q).

Capabilities and Features

Major system components:

- a. Impedance Bridge
- b. Power cable
- c. Spare fuse

Seven function settings for R, L, C, D, and Q

Seven ranges for each function

Four digit resolution for R, L, and C

Automatic decimal point

Single dial for D and Q measurements

Automatic balance circuit for D and Q

Automatic null direction indicator

Accuracy of plus or minus (PORM) 1 percent (PCT)

1-11. LOCATION AND DESCRIPTION OF MAJOR COMPONENTS.

The location and description of major components for the impedance bridge are shown in figure 1-2.

IMPEDANCE BRIDGE. The ZM-71A/U measures capacitance from 1pF to 1000uF in seven ranges, inductance from 1uH to 1000H in seven ranges, resistance from 10 milliohms to 10 megohms in seven ranges, capacitor dissipation factor from 0.001 to 20 in two ranges, and inductance quality factor from 0.05 to 1000 in two ranges. All operator controls are located on the front and rear panels. The Impedance Bridge is housed in a cabinet 6 by 7 by 11 inches, weighs approximately 11 pounds, and is designed for table top use.

POWER CABLE

Connects the power meter to a 115/230Vac power source. The cable is 7 feet long with a male plug on one end and a female plug on the other end.

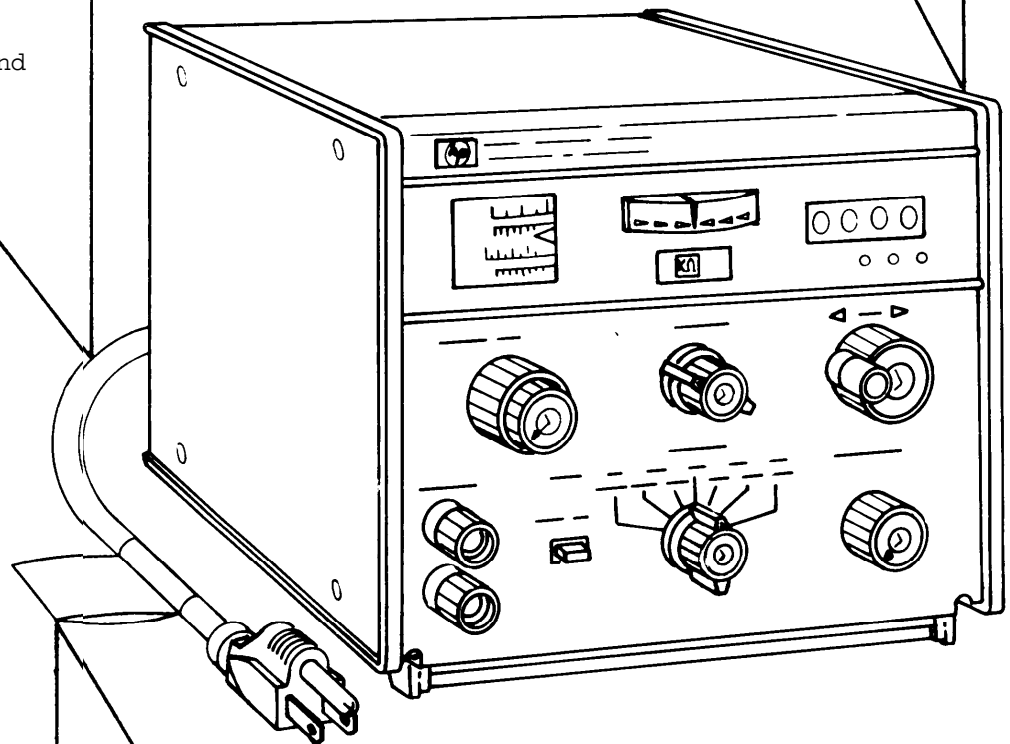

SPARE FUSE

Supplied in an envelope tied to the power cable for use in 115/230VAC operation, 250V, 0.1A, slo-blo.

Figure 1-2. Location and Description of Major Components.

Table 1-1. Equipment Data.

WEIGHTS AND DIMENSIONS

IMPEDANCE BRIDGE

Weight	11 lb (5 Kg)
Length	11 in. (279 mm)
Width	7.781 in. (198 mm)
Height	6.525 in. (165 mm)

POWER CABLE

Weight	5 oz (450 g)
Length	84 in. (2131 mm)

POWER REQUIREMENTS

Voltage	115 or 230 V ac plus or minus 10 percent
Frequency	48 to 66Hz
Power	7 Watts
Fuse	0.1 Amp

PERFORMANCE

Function	7 settings for capacitance series and parallel, inductance series and parallel, and resistance.
Range	7 control settings for each function.
CRL Counter	0000 to 1086 in 0001 increments, with 3 floating decimal points.
DQ Dial	Top scale from 8 to 1000 in various steps for high Q. Second scale from 0.02 to 20 in various steps for low Q. Third scale from 50 to 0.05 in various steps for high D. Bottom scale from 0.12 to 0.001 in various steps for low D.
Accuracy	PORM 1 PCT + 1 digit for 1nF to 100uF, 1mH to 100H, and 10 ohms to 1 megohm PORM 2 PCT + 1 digit for 1pF to 1nF, 1uH to 1000H, 10 milliohms to 10 ohms, and 1 megohm to 10 megohms.
Operating Temperature	0 to +55 DEG C.

CHAPTER 2 OPERATING INSTRUCTIONS

SECTION I. DESCRIPTION AND USE OF OPERATOR CONTROLS AND INDICATORS

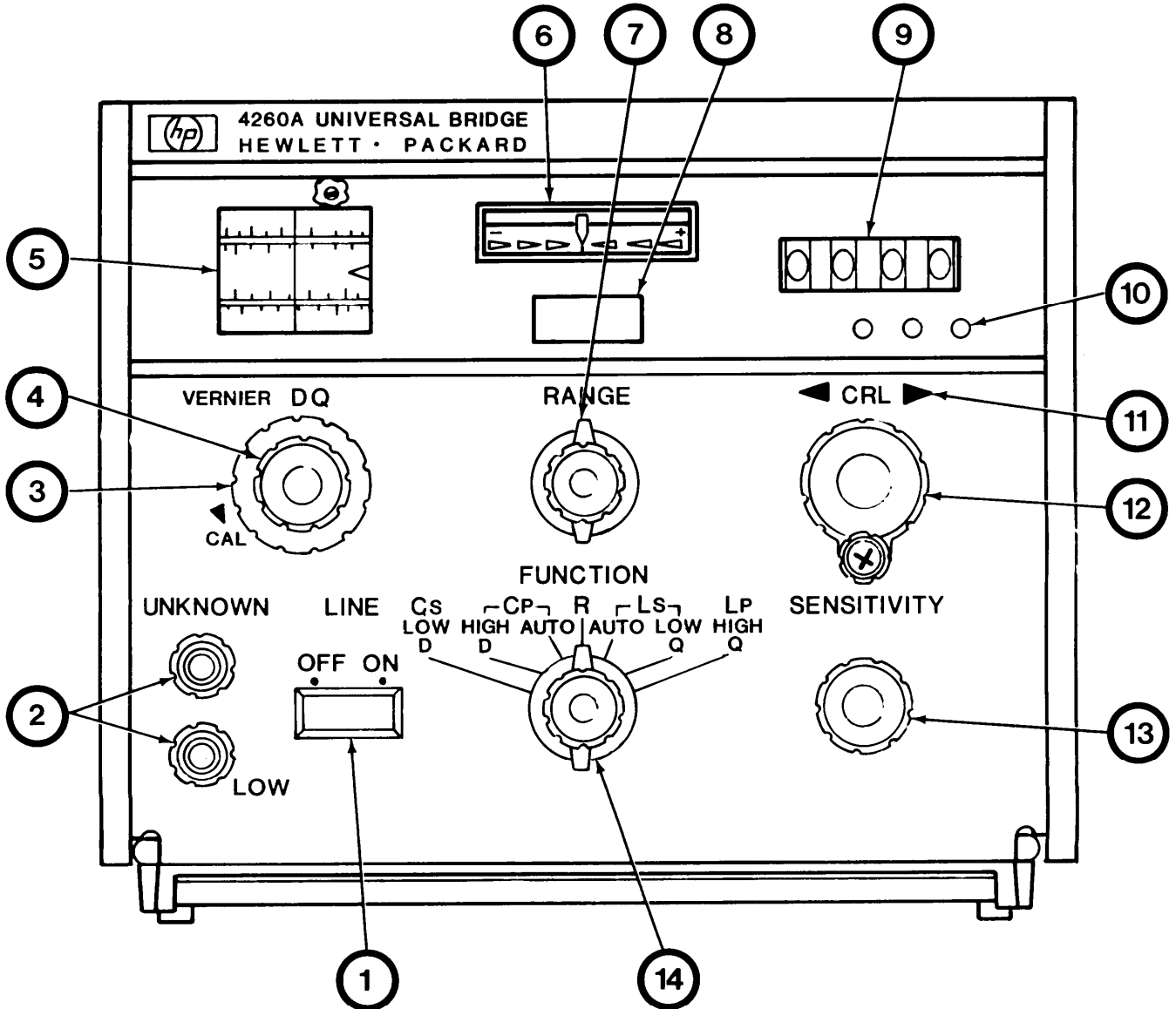

Figure 2-1. Description and Use of Operator Controls and Indicators, front view.

KEY	CONTROL OR INDICATOR	FUNCTION
1	Power switch	Turns ZM-71A/U impedance bridge ON and OFF. Connects 115/230 V ac line voltage to the ZM-71A/U. Push in for ON, out for OFF.

KEY	CONTROL OR INDICATOR	FUNCTION
2	UNKNOWN terminals	<p>Used to connect the leads of the component to to be measured.</p> <p>Connects the component to be measured to the internal circuits of the ZM-71A/U.</p> <p>Binding post type connectors can be loosened to allow direct mounting, or banana type test leads can be connected to the center hole.</p>
3	DQ control (Outer knob)	<p>Controls the position of the DQ dial.</p> <p>Mechanically connected to the DQ dial and controls internal electrical circuits.</p> <p>Outer black knob mechanically moves the DQ dial (5). Clockwise rotation moves the DQ dial from left to right decreasing the value of Q, and increasing the value of D.</p>
4	DQ VERNIER control (Inner knob)	<p>Prevents false nulls caused by lack of resolution with DQ control (3) when measuring D and Q.</p> <p>Electrically adjusts internal circuits when measuring large D or small Q.</p> <p>Red knob turned fully counterclockwise is in CAL position. (Does not mechanically mode the DQ dial (5).</p>
5	DQ dial	<p>Indicates the value of capacitor dissipation factor (D) or inductance quality factor (Q).</p> <p>Position of the DQ dial is controlled by DQ control (3). Red pointer controlled by the FUNCTION switch (14) indicates which scale is used. Top scale is used for high Q, second scale is used for low Q, third scale is used for high D, and bottom scale is used for low D.</p>
6	Null meter	<p>Indicates when a proper reading has been reached. Electrically controlled by the CRL control (12).</p> <p>Meter indicates the direction the CRL control must be moved to establish a null or proper reading. In R measurements, indicator moves to + and -. In C and L measurements, indicator deflects to + only.</p> <p>Center position indicates a null condition, left of null is - or below proper value, and right of null is + or above proper value.</p>

KEY	CONTROL OR INDICATOR	FUNCTION
7	RANGE switch	<p>Selects the approximate value of the item being measured.</p> <p>Electrically controls the placement of the decimal point in R, C, and L measurements on the counter(g). Seven position switch. Fully counterclockwise is for small values of R and L and large values of C (ohms, uH, and uF). Fully clockwise is for large values of R and L and small values of C (megohms, H, and pF).</p>
8	RANGE and FUNCTION window	<p>Displays both the RANGE (7) and FUNCTION (14) switch settings.</p> <p>Two plastic disks are mechanically coupled to the RANGE and FUNCTION switches.</p> <p>Range units are displayed as standard electrical measurements (C has pF, nF, and uF; R has ohms, kohms, and mohms; and L has uH, mH, and H).</p> <p>Function units are displayed as standard electrical schematic symbols (C and L have series and parallel circuits and R has no symbol).</p>
9	Numerical counter	<p>Displays the value of C, R, or L.</p> <p>Mechanically driven by the CRL control (12).</p> <p>Four digit odometer type counter with a range from 0000 to 1086. (Upper limit may vary from one impedance bridge to another.)</p>
10	Decimal point indicators.	<p>Use with the numerical counter for the value of C, R, or L.</p> <p>Electrically controlled by the position of the RANGE and FUNCTION switches.</p> <p>One of three lights indicate the value of C, R, or L displayed on the numerical counter (9). If the left light is on, the value on the numerical counter is 00.00; or if the center light is on the value is 000.0; or if the right light is on the value is 0000.</p>
11	Direction lights	<p>Indicates the direction the CRL control (12) must be turned to obtain a proper reading when in Cp AUTO or Ls AUTO functions only.</p> <p>Electrically controlled by the FUNCTION switch and internal measuring circuits.</p> <p>The left light indicates the CRL control must be turned counterclockwise to obtain a lower counter value and the right light indicates the CRL control must be turned clockwise to obtain a higher counter value.</p>

KEY	CONTROL OR INDICATOR	FUNCTION
12	CRL control	<p>Controls the position of the numeric counter (9). Mechanically connected to the numerical counter and controls internal electrical circuits that determine the value of the item being measured. Clockwise rotation increases the value displayed on the counter and counterclockwise rotation decreases the value displayed on the counter.</p>
13	SENSITIVITY control	<p>Controls the sensitivity of the null meter (6). Electrically controls the amount of movement on the meter. Clockwise rotation increases null meter sensitivity, and counterclockwise rotation decreases null meter sensitivity.</p>
14	FUNCTION switch	<p>Selects the type of component to be measured and what measurement is to be performed. Electrically sets up the impedance bridge to measure any of the three types of components and the position of the decimal point. Mechanically coupled to the range and function window (8).</p> <p>Cs/LOW D is for measurement of low capacitor dissipation factor and connects the component in a series circuit, Cp/HIGH D is for measurement of high capacitor dissipation factor and connects the component in a parallel circuit, Cp/AUTO is to determine the value of a capacitor, R is to determine the value of a resistor, Ls/AUTO is to determine the value of an inductor, Ls/LOW Q is for measurement of low inductance quality factor and connects the component in a series circuit, and Lp/HIGH Q is for measurement of high inductance quality factor and connects the component in a parallel circuit.</p>

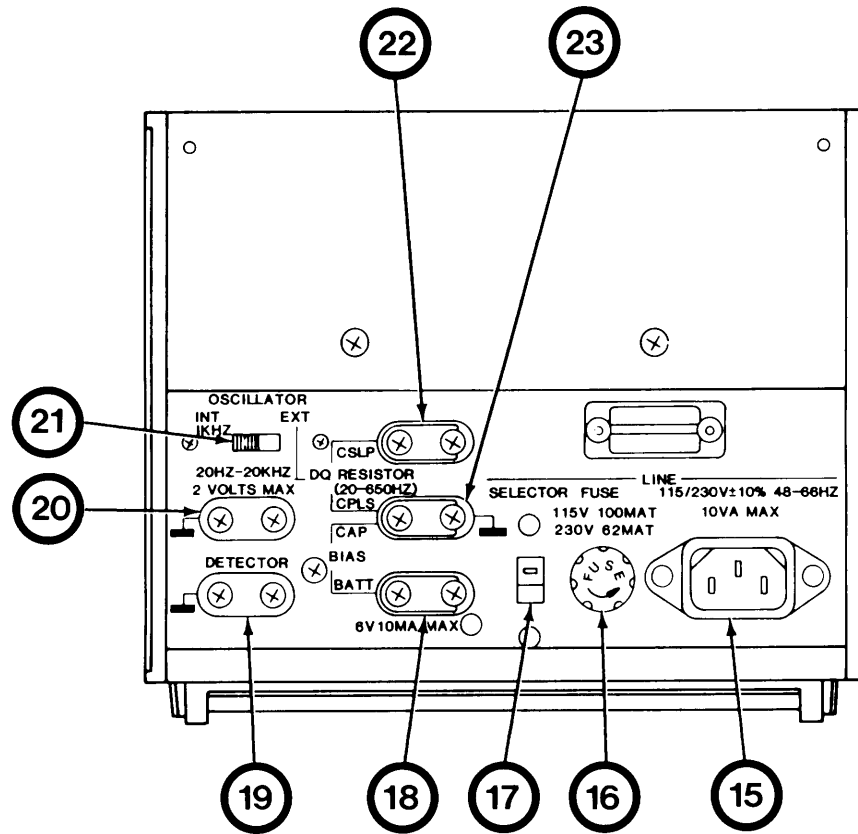

Figure 2-2. Description and Use of Operator Controls and Indicators, rear view.

KEY	CONTROL OR INDICATOR	FUNCTION
15	Power cable input	Connects the power cable (supplied) to the impedance bridge. Line voltage from input connector applied to fuse for distribution to internal circuits of impedance bridge. Three male pins with two index keys at the top.
16	Fuseholder	Holds the 0.1 amp fuse. Protects the impedance bridge from external line surges or internal short circuits. Push in and rotate counterclockwise to remove fuse.
17	Line voltage switch	Selects voltage to be used to power the impedance bridge. Allows 115 or 230 V ac line voltage to be applied to the internal circuits of the impedance bridge. Two position slide switch. Push up for 115 V and down for 230 V.

KEY	CONTROL OR INDICATOR	FUNCTION
18	BIAS BATTERY terminals	<p>Connects an external battery (up to 6V maximum) for use in C and L measurements requiring DC bias.</p> <p>Electrically connects the component being measured and the external battery to the internal circuits of the impedance bridge. Battery terminals are connected with positive (+) on the right and negative (-) on the left. Leave the shorting strap in place for normal use.</p>
19	DETECTOR output terminals	<p>Signal that can be used for an external tuned amplifier or connected to an oscilloscope. Amount of signal is dependent on the position of the CRL control(11).</p> <p>Right terminal is signal output, and left terminal is ground. Leave open for normal use.</p>
20	External oscillator terminals	<p>Connects an external oscillator to the impedance bridge for use in C, L, D, and Q measurements. Allows the use of an external signal, 20Hz to 20kHz 2 volts maximum.</p> <p>Right terminal is for signal input, and left terminal is ground. Leave open for normal use.</p>
21	OSCILLATOR Int/Ext switch	<p>Selects either internal 1KHz oscillator or external oscillator.</p> <p>Internal position uses the internal 1kHz oscillator and the error signal amplifier is tuned to 1KHz. On the external position, an external signal must be introduced to the external oscillator terminals (20) the error signal amplifier response is flat.</p> <p>Two position switch, left is INT and right is EXT.</p>
22	DQ RESISTOR CsLp terminals	<p>Used to connect a variable resistor for special low frequency capacitor dissipation factor or inductance quality factor measurements. Maximum resistance range is 0 to 300,000 ohms. Leave shorting strap in place for normal use.</p>
23	DQ RESISTOR CpLs/bias capacitor terminals	<p>Used to connect a variable resistor for special low frequency capacitor dissipation factor or inductance quality factor measurements. Used to connect a capacitor for C or L measurements when DC bias is required. Maximum resistance range is 0 to 300,000 ohms. Capacitance is calculated. Leave shorting strap in place for normal use.</p>

SECTION II. OPERATOR PREVENTIVE CHECKS AND SERVICES.

2-1. GENERAL.

To be sure that your equipment is always ready for your mission, you must do scheduled preventive maintenance checks and services (PMCS). When you are doing any PMCS or routine checks, keep in mind the WARNINGS and CAUTIONS about electrical shock and bodily harm.

2-2. PMCS TABLE.

A PMCS table for the ZM-71A/U appears in table 2-1. There are five categories or intervals of PMCS: B, D, A, W, and M. They head the INTERVAL columns of the PMCS table. A check mark in one or more of the INTERVAL columns indicates the check and/or service that should be performed by the operator at a particular time.

a. B stands for before. B-PMCS should be performed BEFORE operation to make sure your equipment is ready to go.

b. D stands for during. D-PMCS is performed DURING operation. This will help you spot small troubles before they become big problems.

c. A stands for after. A-PMCS should be performed AFTER operation.

d. In general, W-PMCS stands for WEEKLY and M stands for MONTHLY and are important preventive maintenance checks and services you make at those intervals to keep serious problems from suddenly happening.

e. You should perform W-PMCS as well as B-PMCS if:

- You are the assigned operator and have not operated the equipment since the last W-PMCS.
- You are operating the equipment for the first time.

f. If your equipment fails to operate, follow the maintenance instructions in chapter 3.

NOTE

If your equipment must be in operation all the time, check and service those items that can be checked and serviced without disturbing the operation. Make the complete checks and services when the equipment can be shut down.

g. Whenever an equipment is reinstalled after removal for any reason, perform the necessary B-PMCS to be sure that the equipment meets the readiness reporting criteria.

h. Routine checks are not listed as PMCS checks. They are checks such as the following:

- Cleaning.
- Dusting.
- Wiping.
- Checking for frayed cables.
- Storing items not in use.
- Covering unused receptacles.
- Checking for loose nuts, bolts, and screws.

i. Routine checks are things that you should do anytime you see they must be done. If you find a routine check like one of those listed in your PMCS table, it was listed because other personnel reported problems with this item.

Table 2-1. Operator Preventive Maintenance Checks and Services.

ITEM NO .	INTERVAL					ITEM TO BE INSPECTED	PROCEDURES CHECK AND HAVE REPAIRED OR ADJUSTED AS NECESSARY	EQUIPMENT IS NOT READY/ AVAILABLE IF:
	B	D	A	W	M			
	X				X	ZM-71A/U	Check for completeness (see appendix C) and operation (see paragraph 2-4).	Upon completion of PMCS checks, available equipment is insufficient to support unit mission.
						IMPEDANCE BRIDGE FRONT		
	X	X			X	Null Meter Glass	Check for punctures or cracks that could permit foreign matter to enter meter mechanism.	Excessive moisture or dirt enters to prevent proper meter operation.
						 <p>CRACKED</p>		
	X	X			X	Knobs	Check for fractures or cracks that could permit slippage of knobs on shafts. Check for proper alignment of function knob to its markings on front panel. Tighten loose setscrews as necessary.	Loose/damaged/missing knobs prevent proper selection of controls.
						 <p>FRACTURED</p>		

Table 2-1. Operator Preventive Maintenance Checks and Services (Continued).

ITEM NO.	INTERVAL					ITEM TO BE INSPECTED	PROCEDURES CHECK AND HAVE REPAIRED OR ADJUSTED AS NECESSARY	EQUIPMENT IS NOT READY/ AVAILABLE IF:
	B	D	A	W	M			
	X	X				X	Switches Check range and function switches for free movement and positive action. Check range function window for proper movement of range and function indicators. Check ON-OFF switch to see that it remains <u>in</u> when on.	Any switch does not function properly (electrically or mechanically).
	X	X				X	Controls Check VERNIER and SENSITIVITY controls for free movement. Check DQ control for free movement and dial variation. Check CRL control for free movement and numerical counter variation from 0000 to approx 1086.	Any control does not function properly (electrically or mechanically).
	X					X	Terminals Check for closed or broken contacts, broken insulator, and stripped threads.	Deffective/damaged terminals prevent proper use or result in safety hazard.

Table 2-1. Operator Preventive Maintenance Checks and Services (Continued).

ITEM NO.	INTERVAL					ITEM TO BE INSPECTED	PROCEDURES CHECK AND HAVE REPAIRED OR ADJUSTED AS NECESSARY	EQUIPMENT IS NOT READY/ AVAILABLE IF:
	B	D	A	W	M			
3						IMPEDANCE BRIDGE REAR		
		X				Connector and Terminals	Check for closed or broken contacts, broken insulators, stripped threads, and missing screws, and shorting bars.	Defective/damaged connector/terminals prevent proper use or result in safety hazard.
					X	Switches	Check oscillator and voltage select switches for free movement and positive action.	Switch does not function properly (electrically or mechanically).
		X				Fuseholder	Check for open fuse, broken contacts, and broken insulator.	Set inoperable.
4						ACCESSORIES		
		X				Cable	Check for frayed wires and closed or broken contacts.	Damaged contacts/ insulation impairs proper operation.

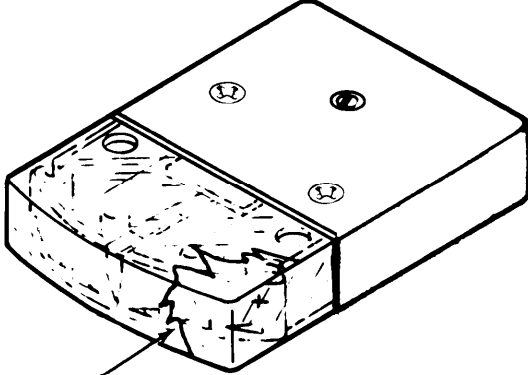
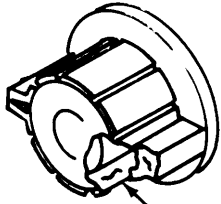
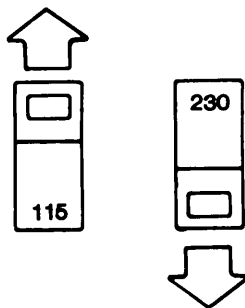
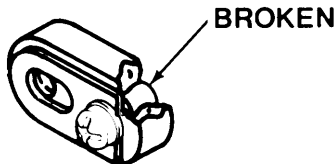

SECTION III. OPERATION UNDER USUAL CONDITIONS

2-3. PREPARATION FOR USE.

a. Set the impedance bridge controls as follows:

- (1) power switch (1) OFF (out).
- (2) FUNCTION switch (12) to the type of measurement to be made as follows:
[Cs LOW D (14) or Cp HIGH D (15) for capacitor dissipation factor,
Cp AUTO (13) for capacitor measurement,
R (4) for resistance measurement,
Ls AUTO (11) for inductor measurement,
Ls LOW Q (10) or Lp HIGH Q (8) for inductance quality factor.
- (3) SENSITIVITY control (9) almost fully counterclockwise (about 5 DEG from fully counterclockwise).
- (4) RANGE switch (5) to mid range.
- (5) CRL control (7) for a numerical counter (6) reading of 1030.
- (6) DQ VERNIER control (3) fully counterclockwise to CAL (2).
- (7) Line voltage selector switch (20) to the line voltage present at your location (115/230VAC).
- (8) OSCILLATOR switch (17) to INT 1kHz (16).
- (9) DQ resistor CsLp terminal (18) with shorting strap in place.
- (10) DQ resistor CpLs/BIAS capacitor terminal (19) with shorting strap in place.
- (11) BIAS BATTERY terminal (21) with shorting strap in place.
- (12) DETECTOR output terminal (22) open.
- (13) External oscillator terminal (23) open.

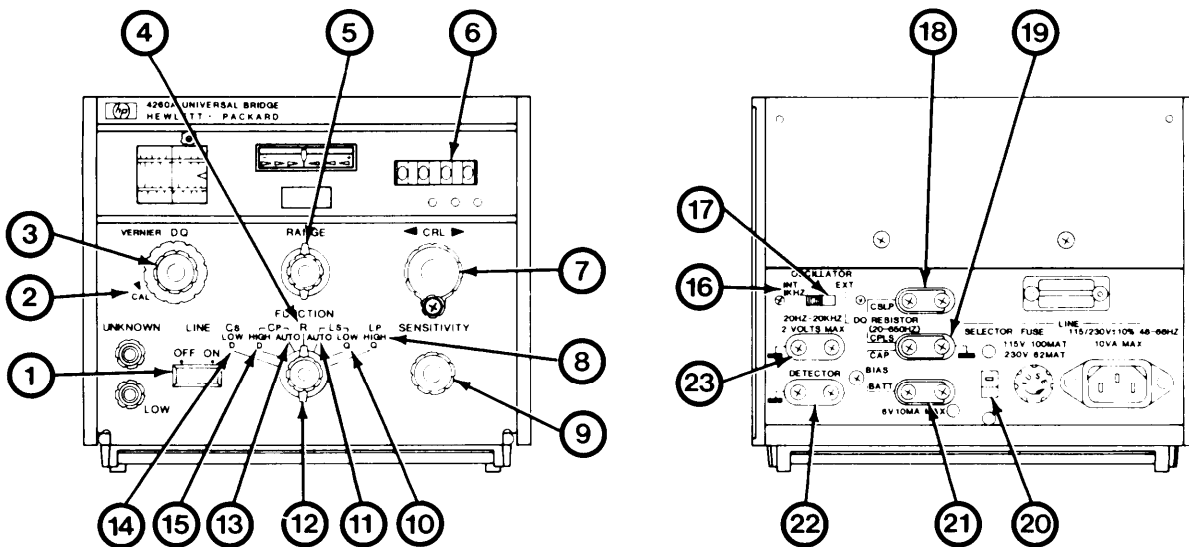

2-4. OPERATING PROCEDURE.

- a. If the null meter pointer (1) is not centered, adjust as follows:
- (1) Make sure no power is applied to the impedance bridge and that the power switch is OFF (out). If power has recently been removed, allow 30 seconds for internal electrical circuits to discharge.
 - (2) Remove the two screws (RPSTL figure 1, item 18) that hold the top cover to the rear panel. Slide the top cover (RPSTL figure 1, item 14) to the rear and remove.
 - (3) Locate null meter zero adjustment screw (3) in the center of the null meter. Rotate the adjustment screw clockwise until null meter pointer (1) approaches zero mark (2) from the left.
 - (4) Continue the clockwise rotation until null meter pointer (1) is directly over zero mark (2). If the pointer overshoots the mark, continue rotating adjusting screw (3) clockwise until the pointer once again approaches the zero mark from the left.
 - (5) Rotate adjustment screw (3) counterclockwise (about 5 degrees) until it releases from the meter suspension. If null meter pointer (1) moves off zero mark (2), repeat steps 3 and 4.
 - (6) Replace the top cover (RPSTL figure 1, item 14).

NOTE

This is the only operator adjustment located inside the case.

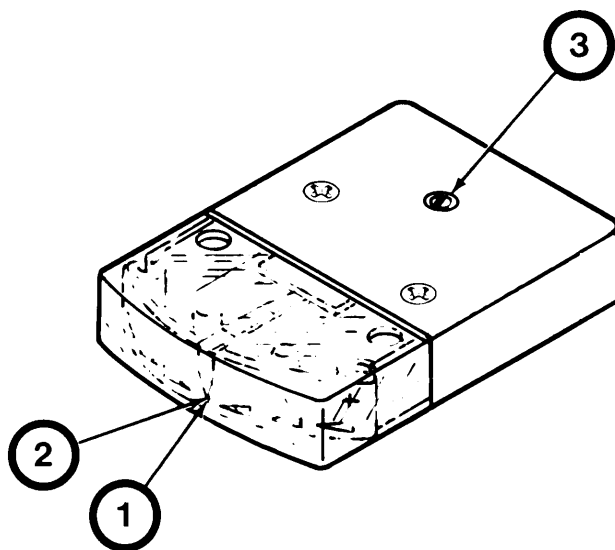

- b. Connect power cable (1) to power input connector (2). Push in power switch (3). The power switch button should remain in and one of the decimal points should glow.

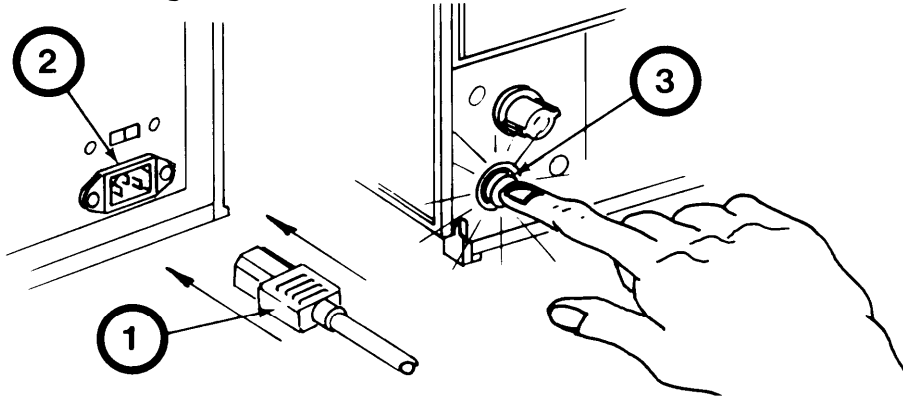

NOTE

Wait about two minutes for the impedance bridge to stabilize before proceeding to the next step.

2-5. POWER.

Power applied to an unknown resistor will vary depending upon the value of the unknown resistor. Maximum open circuit voltage at the UNKNOWN terminals is 40 Vdc. Maximum short circuit current through the UNKNOWN terminals is 25mA. These values are effected by the RANGE switch position, CRL control setting, and the unknown value. Voltage across the unknown resistor can be measured with a high input impedance voltmeter. Current through an unknown resistor can be measured with an ammeter.

2-6. RESISTANCE MEASUREMENT.

Resistance values between 100 ohms and 10,000 ohms can be measured with 1 percent accuracy by following the instructions given below. For 1 percent accuracy of values below 100 ohms and above 10,000 ohms, see paragraph 2-7 for measurement instructions.

- a. Perform the turn-on procedures listed in paragraph 2-3 and 2-4.
- b. Set FUNCTION switch (10) to R position (11).

NOTE

For best results, resistor leads should be as short as possible and secured tightly to the binding posts to reduce contact resistance. Short heavy leads should be used whenever possible to reduce lead resistance.

- c. Connect the resistor to be measured to UNKNOWN terminals (12).

RESISTOR MEASUREMENT

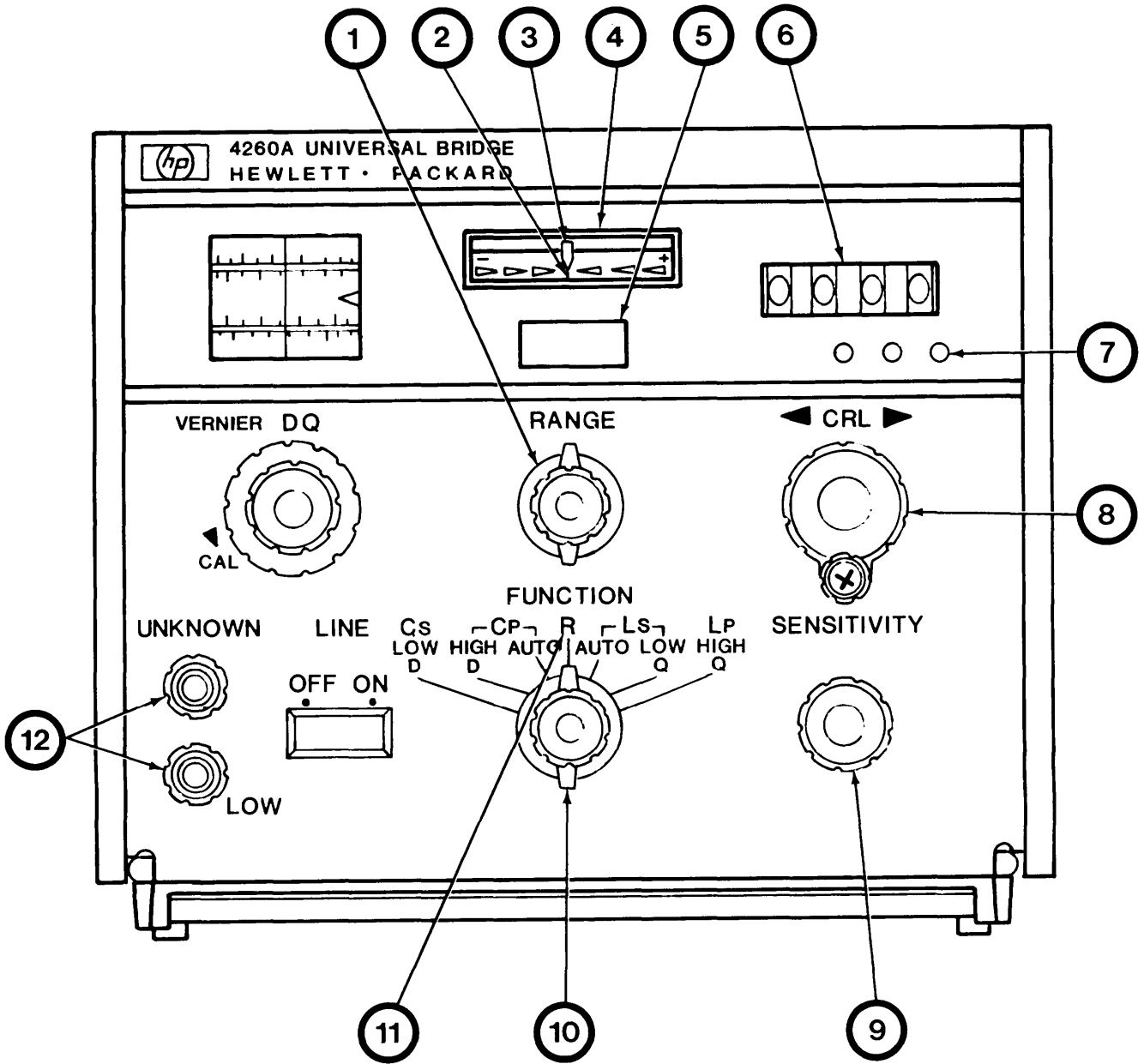

- d. Rotate SENSITIVITY control (9) clockwise until null meter (4) deflects 1 scale mark from null meter zero mark (2).
- e. If null meter pointer (3) moves left (towards -), turn RANGE switch (1) clockwise until the pointer moves closer to null meter zero mark (2).
- f. If null meter pointer (3) moves right (towards +), turn RANGE switch (1) counterclockwise until the pointer moves closer to null meter zero mark (2).
- g. Rotate SENSITIVITY control (9) clockwise until null meter (4) deflects full scale + or -.
- h. If null meter (4) indicates a negative (-) full scale deflection, turn CRL control (8) clockwise for a zero indication on the null meter. If the null meter indicates a positive (+) full scale deflection, turn the CRL control counterclockwise for a zero indication on the null meter.
- j. Rotate SENSITIVITY control (9) fully clockwise and adjust CRL control (8) for a zero indication on null meter (4).
- k. Read the value of the resistor on numerical counter (6) taking care to note the position of decimal point (7) and the value in range and function window (5).

Example: Numerical counter (6) with decimal point (7) reads 01.98 with range and function window (5) set at Kohms. The value of the resistor is 1.98K ohms or 1,980 ohms.

NOTE

For maximum resolution, the final numerical counter reading should be greater than 0100. Subtract resistor lead resistance from the numerical counter reading.

1. Rotate SENSITIVITY control (9) fully counterclockwise and remove the resistor.

2-7. RESISTANCE MEASUREMENT.

To perform resistance measurements below 100 ohms and above 10,000 ohms, a sensitive DC null meter is required. Disconnect the shorting strap (if any) on the DC null meter to remove the common terminal from ground to avoid ground loops.

- a. Perform the turn-on procedures listed in paragraph 2-3 and 2-4.
- b. Connect the external DC null meter as follows:
 - (1) Connect the DC null meter common/ground/low terminal to the detector terminal ground.
 - (2) Connect the DC null meter input terminal to unknown Low terminal (12).

- c. Set FUNCTION switch (10) to R position (11).

NOTE

For best results, resistor leads should be as short as possible and secured tightly to the binding posts to reduce contact resistance. Short heavy leads should be used whenever possible to reduce lead resistance.

- d. Connect the resistor to be measured to UNKNOWN terminals (12).
- e. Rotate SENSITIVITY control (9) clockwise until null meter (4) deflects from null meter zero mark (2).
- f. If null meter pointer (3) moves left (towards -), turn RANGE switch (1) clockwise until the null meter pointer moves closer to null meter zero mark (2).
- g. If null meter pointer (3) moves right (towards +), turn the RANGE switch (1) counterclockwise until the null meter pointer moves closer to null meter zero mark (2).
- h. Rotate SENSITIVITY control (9) clockwise until null meter (4) deflects full scale + or -.
- j. If null meter (4) indicates a left full scale deflection, turn CRL control (8) clockwise for a zero indication on the null meter. If the null meter indicates a right full scale deflection, turn the CRL control counterclockwise for a zero indication on the null meter.
- k. Rotate SENSITIVITY control (9) fully clockwise and adjust CRL control (8) for a zero indication on null meter (4).
- l. Read the value of the of the resistor on numerical counter (6) taking care to note the position of decimal point (7) and the value in the range and function window (5).

Example: Numerical counter (6) with decimal point (7) reads 01.98 and range and function window (5) set at Mohms. The value of the resistor is 1.98M ohms or 1,980,000 ohms.

NOTE

For maximum resolution, the final numerical counter reading should be greater than 0100. Subtract resistor lead resistance from the numerical counter reading.

- m. Rotate SENSITIVITY control (9) fully counterclockwise and remove the resistor.
- n. Disconnect the DC null meter.

2-8. CAPACITANCE.

- a. Capacitance measurements are normally made at a frequency of 1KHz from the internal oscillator. For capacitance measurements at frequencies between 20 Hz and 20 KHz an external oscillator is needed. See paragraph 2-17 for instructions .
- b. Direction lights above the CRL control indicate the correct direction the CRL control must be turned. The null meter pointer will only move right (towards +).
- c. Residual capacitance of the UNKNOWN terminals can be measured with nothing connected to the UNKNOWN terminals. Set the FUNCTION switch to Cp AUTO and the RANGE switch to pF. With nothing connected to the UNKNOWN terminals, rotate the CRL control until a null is indicated. A typical value of residual capacitance is about 2 pF or less.
- d. If external leads are used, connect them to the UNKNOWN terminals and perform the measurement for residual capacitance.
- e. To measure voltage across a capacitor a vacuum tube voltmeter is needed. Measure the voltage as follows:
 - (1). Perform the procedures listed in para 2-9 and leave the impedance bridge set-up at null.
 - (2). Isolate the voltmeter from ground by using two-prong power cord adapter and leave the adapter pigtail disconnected from ground.
 - (3). Connect the voltmeter input ground terminal to the impedance bridge detector ground terminal.
 - (4). Connect the voltmeter input terminal to the impedance bridge UNKNOWN terminal (not the LOW terminal).
 - (5). Read the voltage on the voltmeter.

2-9. CAPACITANCE MEASUREMENTS.

- a. Perform the turn-on procedures listed in para 2-3 and 2-4.
- b. Set FUNCTION switch (10) to Cp AUTO (11) position.

WARNING

DISCHARGE THE CAPACITOR TO BE MEASURED BEFORE
CONNECTING IT TO THE UNKNOWN TERMINALS.

- c. Connect the capacitor to be measured to UNKNOWN terminals (14).
- d. Rotate SENSITIVITY control (9) fully clockwise.

CAPACITOR MEASUREMENT

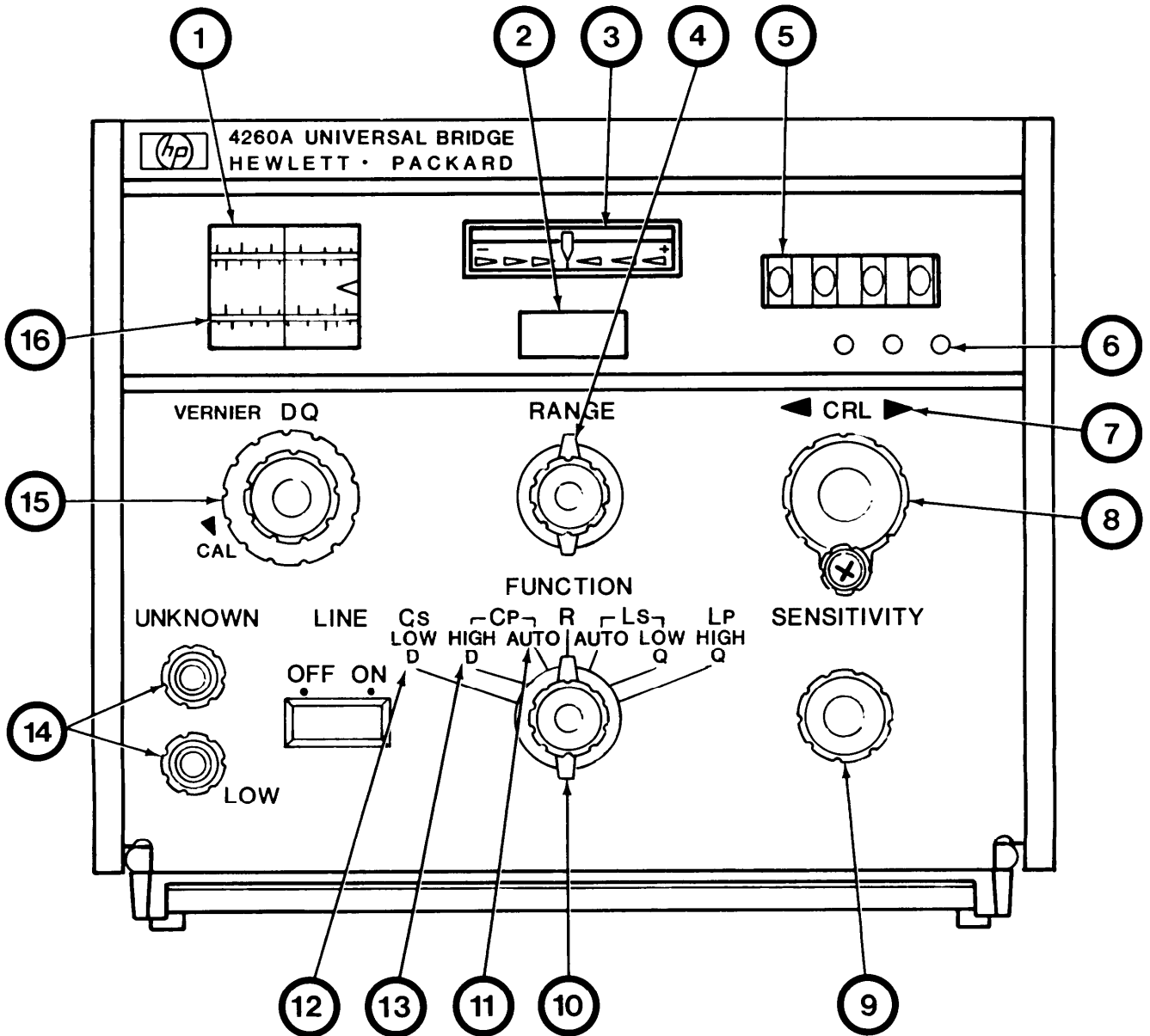

- e. Rotate RANGE control (4) until direction indicator (7) alternates left and right. Leave the RANGE switch on the setting that lights the left direction indicator if possible. If the direction indicator lights only the left light when turning the RANGE switch, leave the RANGE switch on the pF position. If the direction indicator lights only the right light when turning the RANGE switch, leave the RANGE switch on the highest uF position.
- f. Rotate CRL control (8) the direction shown by direction indicator (7) until a zero is indicated on null meter (3). If the left light is on, rotate the CRL control counterclockwise to decrease the value. If the right light is on, rotate the CRL control clockwise to increase the value.

NOTE

The direction indicator is very sensitive and will switch to the other direction quickly. It is best to get close to the value with the direction indicator and then zero with the null meter.

- g. Read the value of the capacitor on numerical counter (5) taking care to note the position of decimal point (6) and the value in range and function window (2). Subtract the residual capacitance from this reading and that is the value of the capacitor.

Example: Numerical counter (5) with decimal point (6) reads 019.2. Range and function window (2) is set at uF. Residual capacitance is 1 pF. The value of the capacitor is .000019199999 farads or 19.199999 uF.

NOTE

For maximum resolution, the final numerical counter reading should be greater than 0100.

- h. Rotate SENSITIVITY control (9) fully counterclockwise and remove the capacitor.

2-10. CAPACITOR DISSIPATION.

- a. The DQ dial overlaps capacitor dissipation from 0.05 to 0.12 on the Cs and Cp FUNCTION settings. The difference between Cs and Cp is large when capacitor dissipation is greater than 0.1. Cs is within 1 PCT of Cp when capacitor dissipation is less than 0.1.
- b. The DQ VERNIER control provides fine electrical adjustment during capacitor dissipation factor measurements. The DQ VERNIER control helps prevent false nulls and does not vary the DQ dial. It is useful only when measuring large capacitor dissipation factors.

2-11. CAPACITOR DISSIPATION MEASUREMENTS.

- a. Perform the turn-on procedures listed in paragraph 2-3 and 2-4.

- b. Perform the capacitance measurement procedure as shown in paragraph 2-9. Do not remove the capacitor being measured from the unknown terminals. Leave the impedance bridge set-up at null.

NOTE

The capacitor dissipation factor must be measured after capacitance measurement has been performed. Do not change the setting of the CRL control or range switch at this time.

- c. Set FUNCTION switch (10) to Cp HIGH D (13) position.
- d. Rotate SENSITIVITY control (9) fully clockwise.
- e. Rotate DQ control (15) for a minimum indication on null meter (3). CRL control (8) may be slightly adjusted for the best null.
- f. If a null indication is impossible, set the FUNCTION switch to Cs LOW D (12). Rotate DQ control (15) for a minimum indication on null meter (3). CRL control (8) may be slightly adjusted for the best null.

NOTE

For large capacitor dissipation factors (5 to 50) using the dq vernier control with the dq control helps to obtain a null.

- g. Read the value of the of the capacitor dissipation factor on DQ dial (1) taking care to note the position of red pointer.

Example: Lower scale (16) on DQ dial indicates .08. The value of the capacitor dissipation factor is 0.08.

- h. Rotate SENSITIVITY control (9) fully counterclockwise and remove the capacitor.

2-12. INDUCTANCE.

- a. Inductance measurements are normally made at a frequency of 1KHz from the internal oscillator. For inductance measurements at frequencies between 20 Hz and 20 KHz, an external oscillator is needed. See paragraph 2-17 for instructions.
- b. The direction lights above the CRL control indicate the correct direction the CRL control must be turned to zero the null meter. The null meter will only move right (towards +).
- c. Residual inductance of UNKNOWN terminals (13) can be measured with a short circuit on the UNKNOWN terminals. Set FUNCTION switch (12) on Ls AUTO (11) and RANGE switch (2) to uH. With a heavy short wire connected to the UNKNOWN terminals, rotate CRL control (7) until a null is indicated on null meter (3). A typical value of residual inductance is about 1 uH or less .

INDUCTOR MEASUREMENT

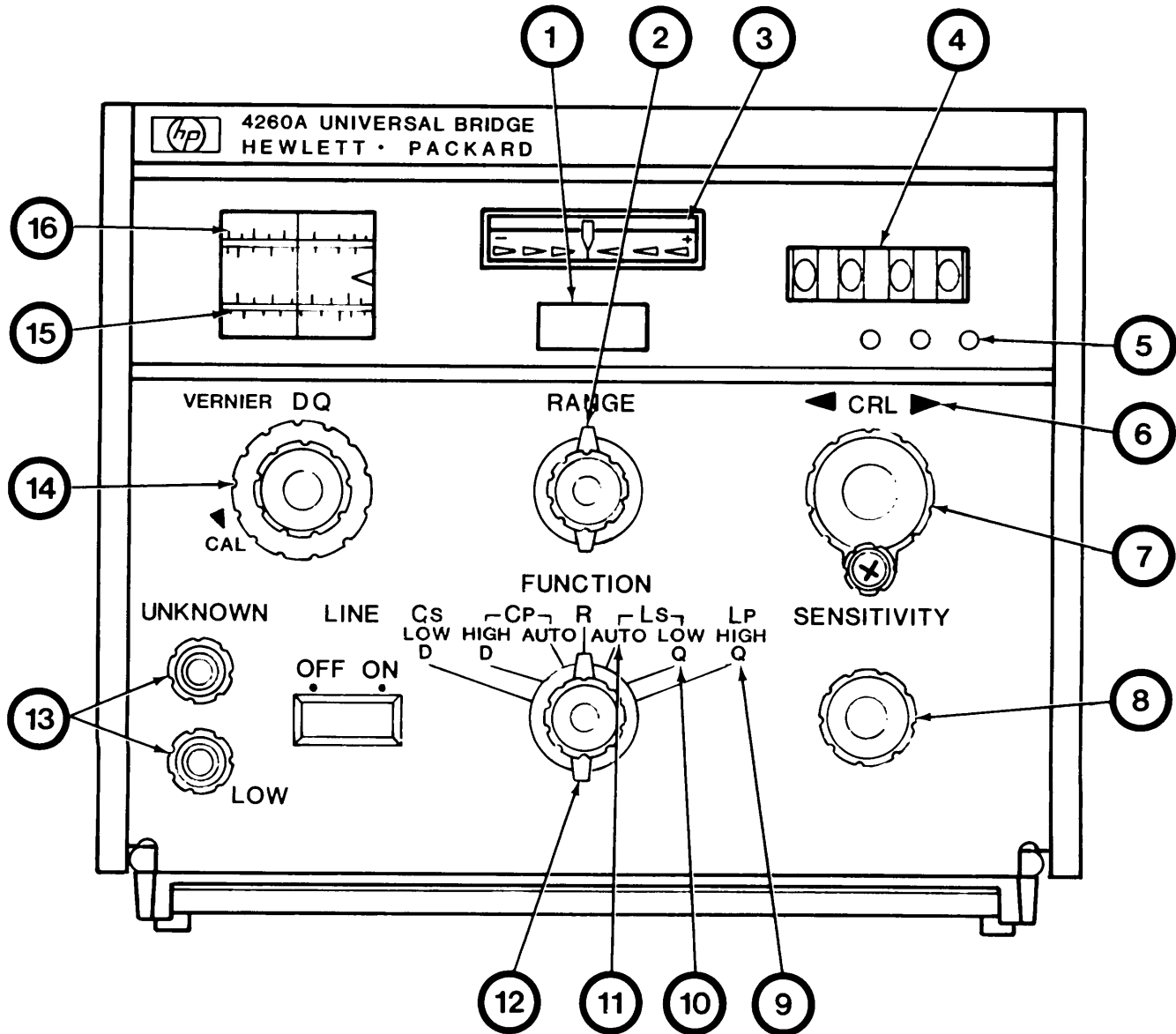

- d. If external leads are used, connect them to the UNKNOWN terminals (13) and perform the measurement for residual inductance.
- e. To measure voltage across an inductor, a vacuum tube voltmeter and a capacitive voltage divider are needed. Measure inductor voltage as follows:
 - 1). Perform the procedures listed in para 2-13 and leave the impedance bridge set-up at null.
 - 2). Isolate the voltmeter from ground by using two-prong power cord adapter and leave the adapter pigtail disconnected from ground.
 - 3). Connect the capacitive divider to the voltmeter.
 - 4). Connect the voltmeter/divider input ground terminal to the impedance bridge detector ground terminal on the rear panel.
 - 5). Connect the voltmeter/divider input terminal to impedance bridge UNKNOWN terminal (13) (not the LOW terminal).
 - 6). Read the voltage on the voltmeter.

2-13. INDUCTANCE MEASUREMENTS.

- a. Perform the turn-on procedures listed in paragraph 2-3 and 2-4.
- b. Set FUNCTION switch (12) to Ls AUTO (11) position.
- c. Connect the inductor to be measured to UNKNOWN terminals (13).
- d. Rotate SENSITIVITY control (8) fully clockwise.
- e. Rotate RANGE control (2) until direction indicator (6) alternates left and right. Leave the RANGE switch on the setting that lights the left direction indicator if possible. If only the left direction indicator lights when turning the RANGE switch, leave the RANGE switch on the uH position. If only the right direction indicator lights when turning the RANGE switch, leave the RANGE switch on the highest H position.
- f. Rotate CRL control (7) in the direction shown by direction indicator (6) until a zero is indicated on null meter (3). If the left light is on, rotate the CRL control counterclockwise to decrease the value. If the right light is on, rotate the CRL control clockwise or increase the value.

NOTE

The direction indicator is very sensitive and will switch to the other direction quickly. It is best to get close to the value with the direction indicator and then zero with the null meter.

- g. Read the value of the inductor on numerical counter (4) taking care to note the position of decimal point (5) and the value in the range and function window (1). Subtract the residual inductance from this reading and that is the value of the inductor.

Example: Numerical counter (4) with decimal point (5) reads 019.2. Range and function window (1) is set at uH. Residual inductance is 1 uH. The value of the inductor is .000019199999 heneries or 19.199999 uH.

NOTE

For maximum resolution, final numerical reading should be greater than 0100.

- h. Rotate SENSITIVITY control (8) fully counterclockwise and remove the inductor.

2-14. INDUCTANCE QUALITY.

- a. The DQ dial overlaps inductor quality from 8 to 20 on the Ls and Lp FUNCTION settings. The difference between Ls and Lp is large when inductance quality is less than 10, and Ls is within 1 PCT of Lp when inductance quality is more than 10.
- b. The DQ VERNIER control provides fine electrical adjustment during inductance quality factor measurements. The DQ vernier control helps prevent false nulls and does not vary the DQ dial. It is useful only when measuring small inductance quality factors.

2-15. INDUCTANCE QUALITY MEASUREMENTS.

- a. Perform the turn-on procedures listed in paragraph 2-3 and 2-4.
- b. Perform the inductance measurement procedure listed in paragraph 2-13. Do not remove the inductor being measured from the UNKNOWN terminals. Leave the impedance bridge set-up at null.

NOTE

Inductance quality factor must be measured after the inductance measurement has been performed. Do not change the setting of the crl control or RANGE switch at this time.

- c. Set FUNCTION switch (12) to Ls low Q (10) position.
- d. Rotate SENSITIVITY control (8) fully clockwise.
- e. Rotate DQ control (14) for a minimum indication on null meter (3). CRL control (7) may be adjusted slightly for the best null.
- f. If a null indication is impossible, set the FUNCTION switch to Lp high Q (9). Rotate DQ control (14) for a minimum indication on null meter (3). CRL control (7) may be adjusted slightly for the best null.

NOTE

For small inductance quality factors (.02 to .2), use the DQ VERNIER control with the DQ control to obtain a null.

- g. Read the value of the inductance quality factor on DQ dial (16) taking care to note the position of the red pointer.

Example: DQ dial (16) with pointer on lower scale (15) reads 3. The value of the inductance quality factor is 3.

- h. Rotate SENSITIVITY control (8) fully counterclockwise and remove the inductor.

2-16. SHUTDOWN PROCEDURES.

- a. To shutdown the impedance bridge.
 - 1). Turn OFF the power switch. Switch should be in the OUT position.
 - 2). Disconnect any components from the UNKNOWN terminals.
 - 3). Disconnect any components from the rear panel.
 - 4). Check to see that shorting straps are in place on the CsLp terminal, CpLs terminal and the BATTERY terminal.
 - 5). Disconnect the power cable from the line voltage receptacle and the impedance bridge.

2-17. OPERATING INSTRUCTIONS ON DECALS AND INSTRUCTION PLATES.

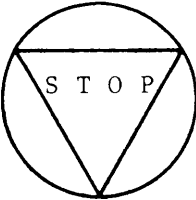
	<p>USE CORRECT VOLTAGE SETTING AND FUSE - SEE MANUAL</p> <p>UTILISER TENSION ET FUSIBLE APPROPRIES - C F MANUEL</p> <p>BENUTZEN SIE KORREKTE SPANNUNGSEIN- STELLUNG UND SICHERUNG - SIEHE MANUAL</p> <p>USE AJUSTE DE VOLTAJE Y FUSIBLE CORRECTO - VEA MANUAL.</p>
---	--

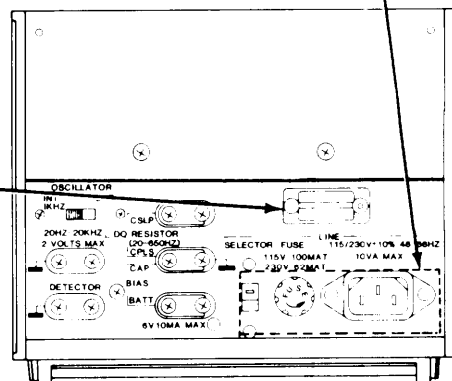
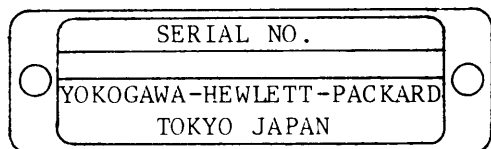

SECTION IV. OPERATION UNDER UNUSAL CONDITIONS

2-18. OPERATION IN EXTREME HEAT AND EXTREME COLD.

- a. Operate the impedance bridge only in a temperature range of 0 to +55 DEG C (32 to 131 DEG F).
- b. Any operation out of the above temperature range may effect the accuracy and/or the operation of the impedance bridge.

2-19. OPERATION IN WET WEATHER.

- a. The impedance bridge will operate normally in 95% humidity at +40 DEG C.
- b. If the impedance bridge has gotten wet (rain, snow, etc), allow it to dry completely before using.
- c. Do not operate the impedance bridge in sea spray.

2-20. OPERATION IN SANDY OR DUSTY AREAS.

- a. Protect the impedance bridge and its accessories from sand and/or dust.
- b. Clean glass surface and contacts whenever they get dirty.

2-21. FORDING.



OPERATING THE IMPEDANCE BRIDGE WHEN WET MAY CAUSE PERMANENT DAMAGE.

- a. Before fording:
 - (1) Place the impedance bridge in a waterproof container with enough padding to keep it from being jarred.
 - (2) Secure the container to a part of the vehicle.
- b. During fording:
 - (1) Take special care to protect the container from anything (cracking/breaking) that would allow water to seep in.
 - (2) Remember that the container will float if not properly secured.
- c. After fording:
 - (1) Unpack the impedance bridge from the container.
 - (2) Check to see if any padding is wet.

- (3) Check to see if any moisture has formed on the impedance bridge.
- (4) If slight moisture is present on the impedance bridge allow it to dry completely before using.

2-22. EMERGENCY PROCEDURES.

- a. Reduction of power. The impedance bridge will operate with power reduced from 115V to 103.5VAC or from 230V to 207VAC. The impedance bridge will not operate properly with any further reduction of power.
- b. Failure of a portion of the impedance bridge. If the impedance bridge fails to operate and you have performed the troubleshooting procedures (paragraph 3-2), notify general support maintenance.

CHAPTER 3

OPERATOR MAINTENANCE INSTRUCTIONS

SECTION 1. LUBRICATION

3-1. LUBRICATION INSTRUCTIONS.

There are no lubrication requirements for the impedance bridge.

SECTION II. TROUBLESHOOTING

3-2. TROUBLESHOOTING PROCEDURES.

Table 3-1 lists common malfunctions which you may find during operation or maintenance of the impedance bridge or its components. You should perform the tests/inspections and corrective actions in the order listed.

This manual cannot list all malfunctions that may occur, nor all tests or inspections and corrective actions. If a malfunction is not listed or is not corrected by listed corrective actions, notify your supervisor.

Table 3-1. Operator's Troubleshooting.

ZM-71.4/U IMPEDANCE BRIDGE.

MALFUNCTION	TEST OR INSPECTION	CORRECTIVE ACTION
1. MECHANICAL METER ZERO DOES NOT ZERO THE METER.	Step 1. Check to see if power is off. Step 2. Check to see if the adjustment screw moves freely.	Turn off power switch. Notify general support maintenance.
2. IMPEDANCE BRIDGE NOT OPERATING.	Step 1. Check to see if the power cable is connected to the power receptacle and to the impedance bridge. Step 2. Check to see if the line voltage select switch is on the proper setting.	Make proper connections (paragraph 2-4b). Set the switch to the voltage available (115 V or 230 V).

Table 3-1. Operator's Troubleshooting (Continued).

MALFUNCTION	TEST OR INSPECTION	CORRECTIVE ACTION
2.	IMPEDANCE BRIDGE NOT OPERATING (Continued).	
	Step 3. Check	to see if the fuse is open/broken. Replace (See section III).
	Step 4. Check	to see if the fuseholder cap is cracked or broken. Replace (See section III).
	Step 5. Check	to see if the power is available at the power receptacle. Move to a working receptacle.
	Step 6. Check	to see if the power cable is open or shorted. Check with an ohmmeter (See section III).
	Step 7. Check	to see if the power switch remains in when pushed and one of the decimal points glows. (paragraph 2-4b). Notify general support maintenance.
3.	RANGE SWITCH KNOB ROTATES ON SHAFT.	
	Step 1. Check	to see if the setscrews are loose. Tighten the setscrews.
	Step 2. Check	to see if the knob is cracked or broken. Replace (See section III).
	Step 3. Check	to see if switch shaft is scored. Notify general support maintenance.
4.	FUNCTION SWITCH KNOB ROTATES ON SHAFT.	
	Step 1. Check	to see if the setscrews are loose. Tighten the setscrews.
	Step 2. Check	to see if the knob is cracked or broken. Replace (See section III).

Table 3-1. Operator's Troubleshooting (Continued).

MALFUNCTION	TEST OR INSPECTION	CORRECTIVE ACTION
4.	FUNCTION SWITCH KNOB	ROTATES ON SHAFT (Continued).
	Step 3. Check	to see if switch shaft is scored.
		Notify general support maintenance.
5.	CRL COUNTER KNOB	ROTATES ON SHAFT.
	Step 1. Check	to see if the setscrews are loose.
		Tighten the setscrews.
	Step 2. Check	to see if the knob is cracked or broken.
		Replace (See section III).
	Step 3. Check	to see if shaft is scored.
		Notify general support maintenance.
6.	SENSITIVITY KNOB	ROTATES ON SHAFT.
	Step 1. Check	to see if the setscrews are loose.
		Tighten the setscrews.
	Step 2. Check	to see if the knob is cracked or broken.
		Replace (See section III).
	Step 3. Check	to see if shaft is scored.
		Notify general support maintenance.
7.	DQ CONTROL KNOB	ROTATES ON SHAFT.
	Step 1. Check	to see if the setscrews are loose.
		Tighten the setscrews.
	Step 2. Check	to see if the knob is cracked or broken.
		Replace (See section III).
	Step 3. Check	to see if shaft is scored.
		Notify general support maintenance.

Table 3-1. Operator's Troubleshooting (Continued).

MALFUNCTION	TEST OR INSPECTION	CORRECTIVE ACTION
8.	DQ VERNIER KNOB ROTATES ON SHAFT.	<p>Check to see if the setscrews are loose. Tighten the setscrews.</p> <p>Check to see if the knob is cracked or broken. Replace (See section III).</p> <p>Check to see if shaft is scored. Notify general support maintenance.</p>
9.	ZM-71A/U WILL NOT MEASURE COMPONENT VALUES.	<p>Check to see if the component is connected to the UNKNOWN terminals securely. Make proper connections.</p> <p>Check to see if the FUNCTION switch is on the proper setting. Set to measurement being performed.</p> <p>Check to see if the RANGE selector is set on incorrect setting. Rotate the RANGE selector to show a lesser deflection on the null meter.</p> <p>Check to see if the SENSITIVITY control is turned down (counterclockwise). Rotate SENSITIVITY control clockwise.</p> <p>Check to see if the oscillator switch is set to INT if no external oscillator is used. Make proper setting.</p> <p>Check to see if the CsLp, CpLs and BATTERY terminals are shorted if no component is being used. Replace shorting straps.</p>

Table 3-1. Operator's Troubleshooting (Continued).

MALFUNCTION	TEST OR INSPECTION	CORRECTIVE ACTION
9.	ZM-71A/U WILL NOT MEASURE COMPONENT VALUES (Continued).	step 7. If leads are used for component hook-up, check to see if they are open. Notify general support maintenance.

SECTION III. MAINTENANCE PROCEDURES

CHECKING THE FUSE.

1. Rotate the fuseholder cap (1) counterclockwise until it stops.
2. Pull out the fuseholder cap (1) and fuse (2).
3. Look at the fuse to see if the small wire inside (3) is burned or broken. Check continuity with an ohmmeter. If replacing the fuse, make sure it is 250V, 0.1 (1/10) AMP, slow blow.
4. To replace the fuse, insert the fuse into the fuseholder cap and place it into the fuseholder.
5. Push in and rotate the fuseholder cap clockwise until it locks.

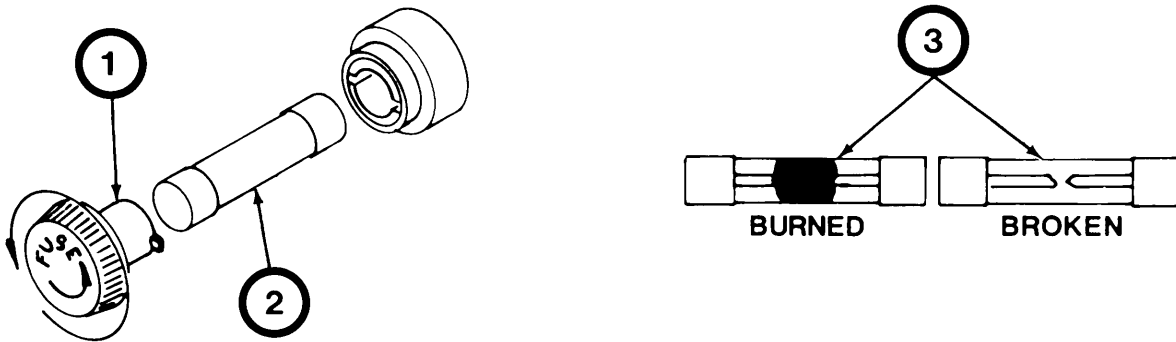

CLEANING ELECTRICAL CONTACTS,

1. If contacts or terminals are tarnished, clean with a cotton swab and a small amount of contact cleaner.
2. If contacts or terminals are burned, first clean with a small file, and then with a cotton swab and a small amount of contact cleaner.

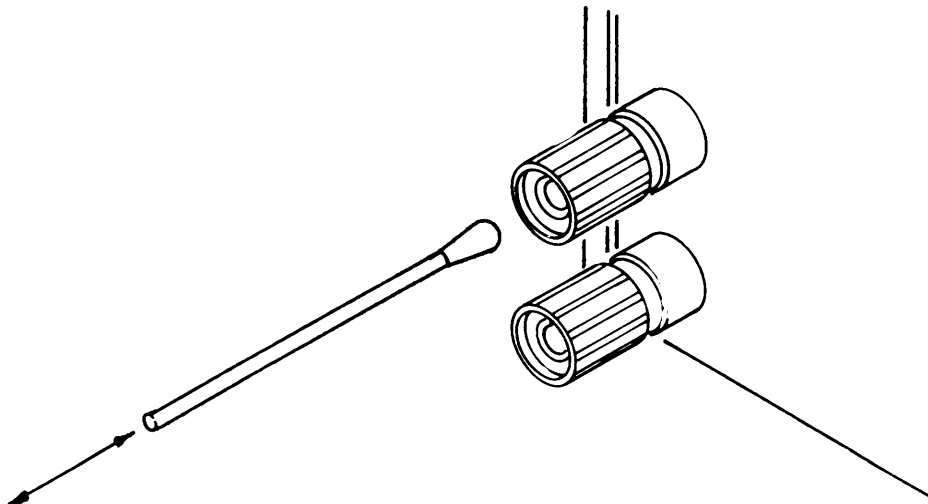

ALIGNMENT OF THE FUNCTION KNOB.

1. Turn the FUNCTION selector switch (1) fully counterclockwise until the shaft stops.
2. Loosen the two hex drive setscrews (2).
3. Rotate FUNCTION selector knob pointer (3) without turning the shaft (4) to the Cs LOW D setting.
4. Tighten the setscrews (2) to secure the knob to the shaft (4).

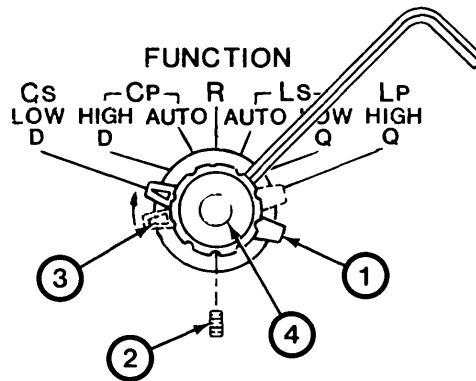

ALIGNMENT OF THE DQ VERNIER KNOB.

1. Turn the DQ VERNIER control (1) fully counterclockwise until the shaft stops.
2. Loosen the two hex drive setscrews (3).
3. Rotate the DQ control knob pointer (4) without turning the shaft (2) to the CAL setting.
4. Tighten the setscrews (3) to secure the knob to the shaft (2).

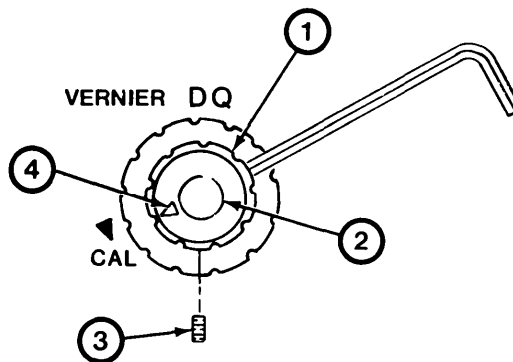

ALIGNMENT OF THE RANGE KNOB.

1. Turn the function selector switch to the R position (1).
2. Turn the RANGE switch (3) fully counterclockwise. Now turn the RANGE switch clockwise one step at a time until the first Kohm appears in the range/function window (2).
3. Loosen the two hex drive setscrews (5).
4. Rotate range switch knob pointer (6) without turning the shaft (4) to point straight up.
5. Tighten the setscrews (5) to secure the knob to the shaft (4).

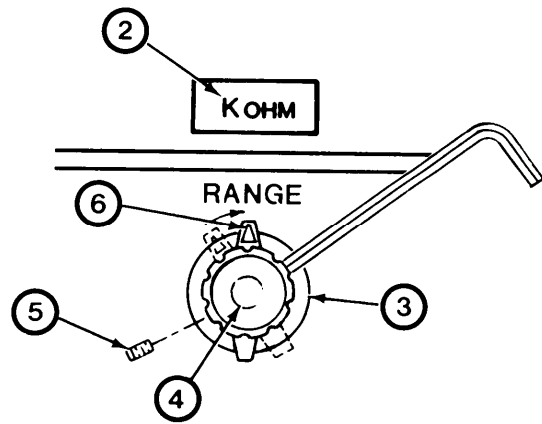
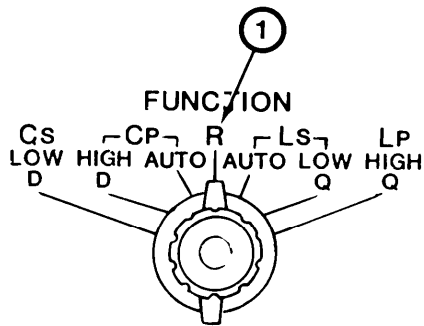

ALIGNMENT OF THE SENSITIVITY KNOB.

1. Turn the SENSITIVITY control (1) fully counterclockwise until the shaft stops.
2. Loosen the two hex drive setscrews (2).
3. Rotate the SENSITIVITY knob pointer (3) without turning the shaft (4) to the 7 o'clock position.
4. Tighten the setscrews (2) to secure the knob to the shaft (4).

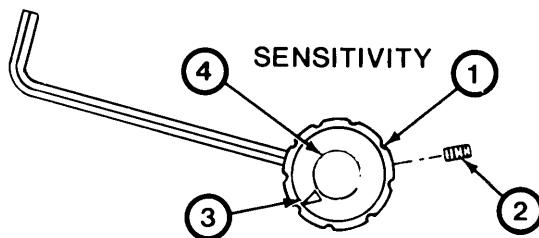

REMOVING/INSTALLING FUNCTION KNOB.

1. If the knob alignment is correct, set the FUNCTION switch pointer (1) to the Cs LOW D setting (4).
2. Loosen the two hex drive setscrews (2).
3. Remove the old knob (3) taking care not to move the shaft (5).
4. Install the new knob (6) on the FUNCTION switch shaft (5) and position the pointer (7) to the Cs LOW D setting.
5. Tighten the setscrews (8) to secure the knob to the shaft (5).

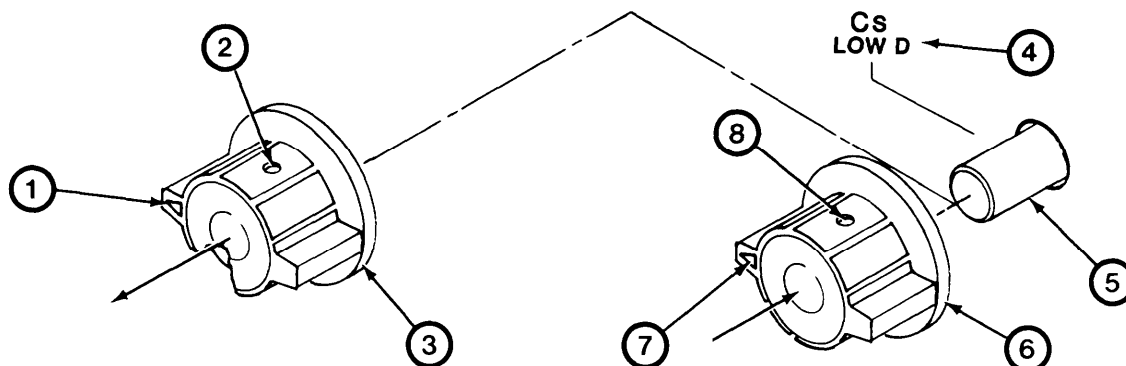
**REMOVING/INSTALLING RANGE KNOB.**

1. If the knob alignment is correct, set the RANGE switch pointer (2) straight up.
2. Loosen the two hex drive setscrews (3).
3. Remove the old knob (1), taking care not to move the shaft (5).
4. Install the new knob (7) on the RANGE switch shaft (5) and position the pointer (4) straight up.
5. Tighten the setscrews (6) to secure the knob to the shaft (5).

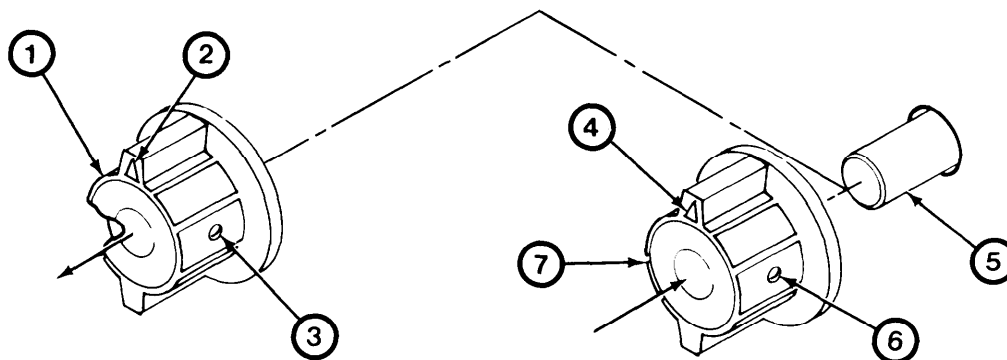

REMOVING/INSTALLING DQ CONTROL KNOB.

1. If the DQ VERNIER knob alignment is correct, set the DQ VERNIER knob pointer (8) to the CAL setting (3).
2. Loosen the two hex drive setscrews (9) on the DQ VERNIER knob (7).
3. Remove the DQ VERNIER knob (7) taking care not to move the shaft (5).
4. Loosen the two hex drive setscrews (2) on the DQ control knob (1).
5. Remove the old knob (1).
6. Install the new knob (10) on the DQ control shaft (4).
7. Tighten the setscrews (6) to secure the DQ control knob to the shaft (4).
8. Install the DQ VERNIER knob (7) on the DQ VERNIER shaft (5) and position the pointer (8) to the CAL setting.
9. Tighten the setscrews (9) to secure the DQ VERINIER knob to the shaft (5).

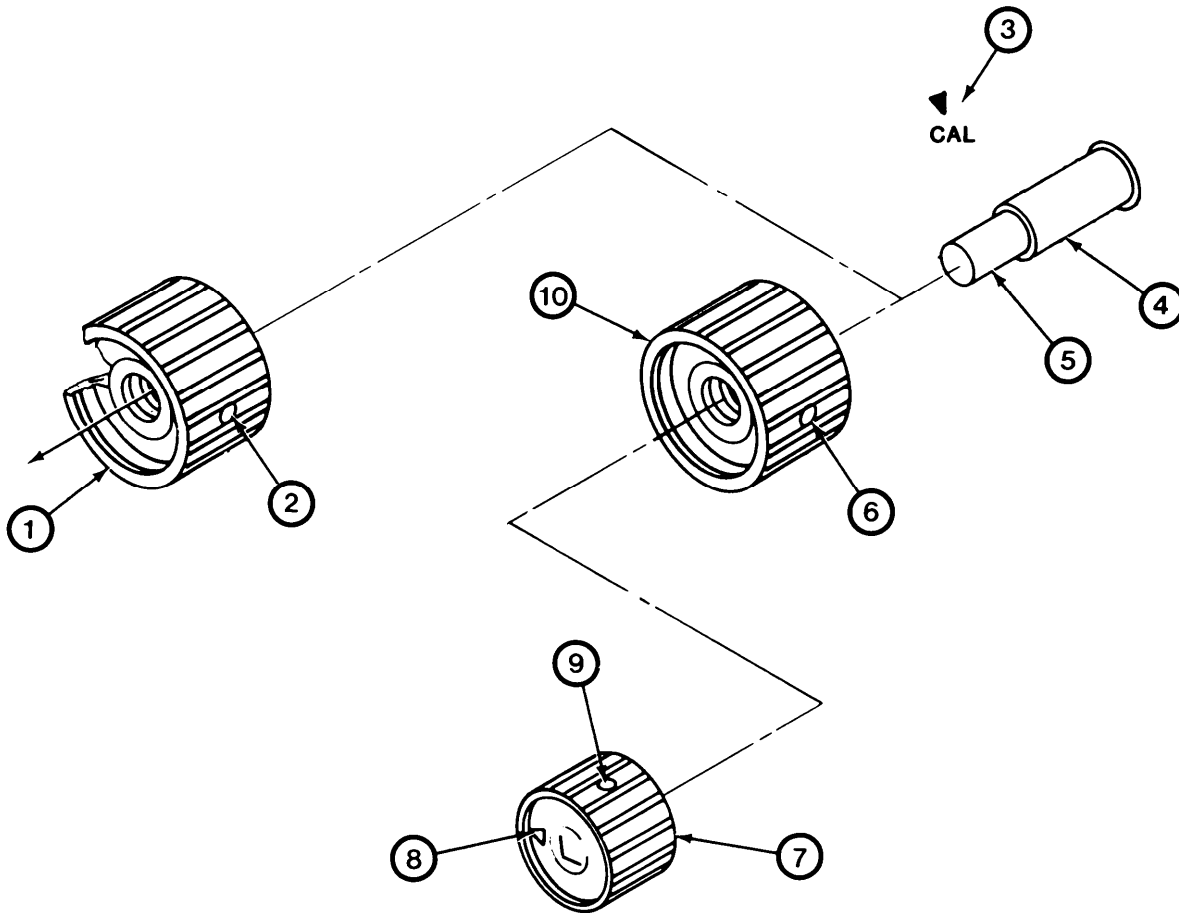

REMOVING/INSTALLING DQ VERNIER KNOB.

1. If the knob alignment is correct, set the DQ VERNIER pointer (1) to the CAL setting (4).
2. Loosen the two hex drive setscrews (3).
3. Remove the old knob (2), taking care not to move the shaft (5).
4. Install the new knob (6) on the DQ VERNIER shaft (5) and position the pointer (7) to the CAL setting.
5. Tighten the setscrews (8) to secure the knob to the shaft (5).

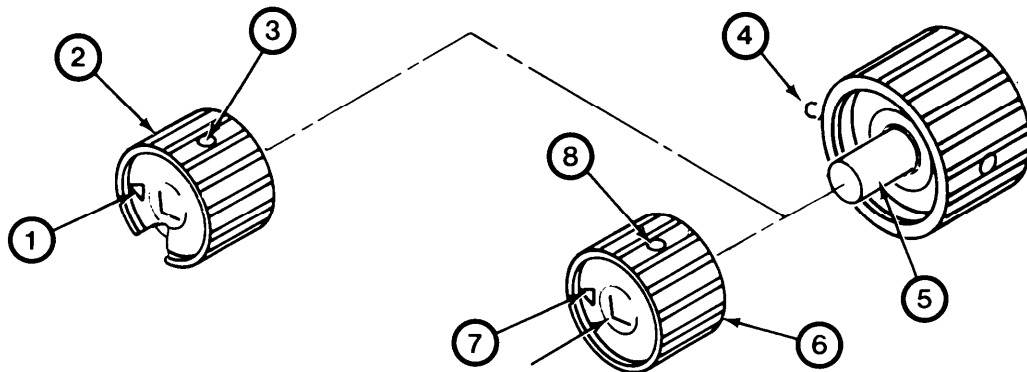

REMOVING/INSTALLING CRL CONTROL KNOB.

1. Loosen the two hex drive setscrews (2).
2. Remove the old knob (1).
3. Install the new knob (3) on the CRL control shaft (4).
4. Tighten the setscrews (5) to secure the knob to the shaft (4).

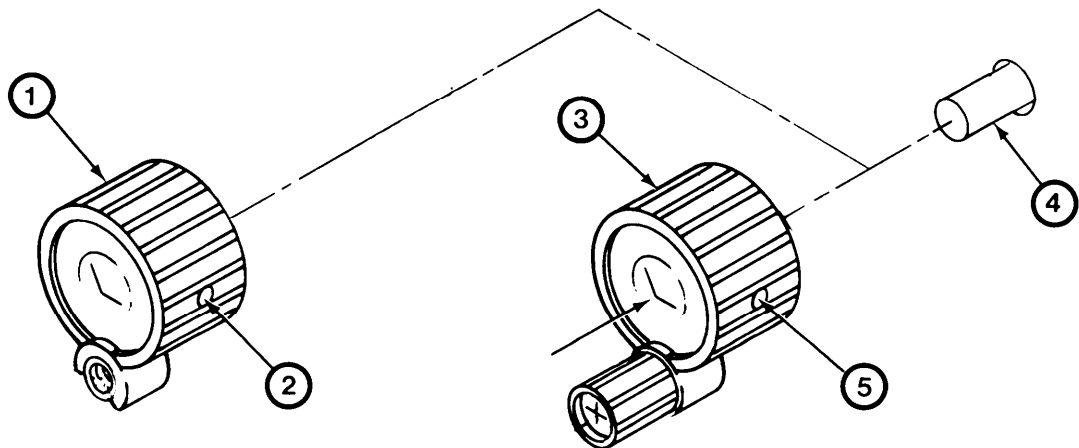

REMOVING/INSTALLING SENSITIVITY KNOB.

1. If the knob alignment is correct, set the SENSITIVITY pointer (2) to the 7 o'clock position.
2. Loosen the two hex drive setscrews (1).
3. Remove the old knob (3) taking care not to move the shaft (4).
4. Install the new knob (7) on the SENSITIVITY shaft (4) and position the pointer (6) to the 7 o'clock position.
5. Tighten the setscrews (5) to secure the knob to the shaft (4).

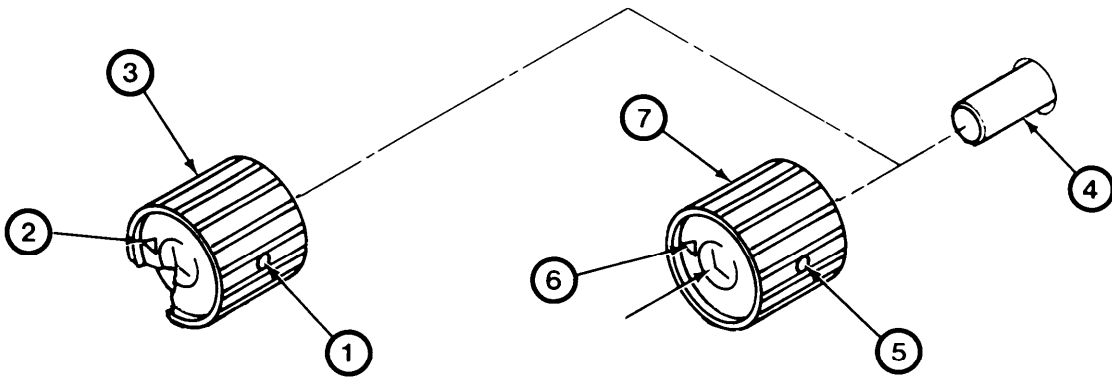

CHECKING CABLES.

1. With an ohmmeter check the continuity of the:
 - A). Power cable (straight pass).

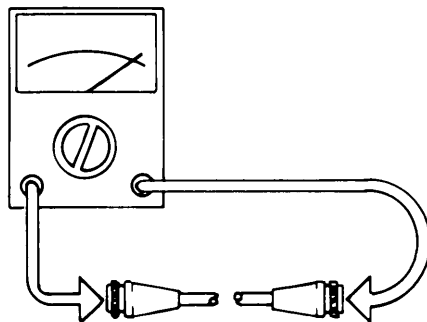

CHAPTER 4

GENERAL SUPPORT MAINTENANCE

4-1. GENERAL.

General support maintenance of impedance bridge, consists of performing preventive maintenance checks and services, troubleshooting malfunctions, removal and replacement of defective parts and assemblies, and alignment.

SECTION I. REPAIR PARTS, SPECIAL TOOLS, TMDE AND SUPPORT EQUIPMENT

4-2. TOOLS AND TEST EQUIPMENT.

Tools, test equipment, and material required for general support maintenance of the impedance bridge are listed in appendix B (Maintenance Allocation).

4-3. REPAIR PARTS.

Repair parts are listed and illustrated in the RPSTL listing (TM 11-6625-3077-24P) covering general support maintenance.

SECTION II. SERVICE UPON RECEIPT

4-4. CHECKING UNPACKED EQUIPMENT.

a. Inspect the equipment for damage incurred during shipment. If the equipment has been damaged, report the damage on SF-364 (Report of Discrepancy) (ROD).

b. Check to see that the equipment is complete as listed on the packing list. Report all discrepancies in accordance with the procedures given in DA Pam 738-750.

c. If the equipment has been modified, check to see whether it has been modified by a Modification Work Order (MWO).

NOTE

Current MWO'S applicable to the equipment are listed in DA PAM 310-1, and DA PAM 750-10.

SECTION III. PRINCIPLES OF OPERATION

4-5. DESCRIPTION.

For capacitance and inductance measurements with the FUNCTION switch set to Cp AUTO or Ls AUTO, a 1KHz signal drives the bridge and balance is achieved by selecting the proper range and adjusting only the CRL control. This is possible because a voltage-controlled resistor is substituted for one resistor in the bridge circuit. Thus, simultaneous adjustment of more than one control is eliminated.

4-6. BLOCK DIAGRAM.

a. Figure FO-1 illustrates the bridge and auto null circuits. The auto null circuits are used when the FUNCTION switch is set to Cp AUTO Ls AUTO position. As seen in figure FO-1, the phase detector receives two signals: 1) an error voltage from the detector amplifier which is proportional to bridge unbalance, and 2) a reference voltage derived from the 1KHz signal source. The phase detector output voltage is therefore proportional to bridge unbalance. This proportional voltage is applied through a dc amplifier to the voltage-controlled resistor circuit. This controlled value is the resistance of the arm of the bridge. As the CRL control is rotated to achieve bridge balance, the voltage-controlled resistor value electronically follows the CRL control. Thus, when bridge balance is achieved, no error voltage is present and the null meter indicates zero.

b. In generating the reference signal input to the phase detector, two voltages are applied to the reference phase comparator. The comparator voltage output has a phase relationship, 0, with respect to the driving signal. The phase multiplier translates this relationship to 20, since 20 is the most effective angle for maximum sensitivity in the circuit. This 20 information is applied to the reference voltage generator and a 1KHz square wave results which is displaced in phase by the driving voltage. The generated 20 reference signal is then applied to the phase detector for comparison with the bridge error voltage.

4-7. BASIC BRIDGE FOR RESISTANCE MEASUREMENTS.

Figure 4-1A shows the basic bridge circuit used to measure resistance. A four-arm bridge circuit is formed by resistors Ra, Rx, Rs, and Rb. Rx is the fixed unknown R to be measured; Ra is determined by the value of Rx; Rs is a fixed value; and Rb is a variable to adjust for bridge balance. In actual use, the impedance bridge circuit is adjusted for a null indication on the meter with the CRL control and the unknown resistance is read directly from the display with correct units and decimal point placement.

4-8. BASIC CIRCUITS FOR CAPACITANCE MEASUREMENTS.

Figure 4-1B illustrates the basic bridge circuit for parallel capacitance (Cp HIGH D) measurements at 1KHz. Figure 4-1C illustrates a basic bridge circuit for series capacitance (Cs LOW D) measurements. For parallel capacitance measurements with the FUNCTION control set to Cp AUTO, the basic bridge circuit is shown in figure 4-1D.

4-9. BASIC CIRCUITS FOR INDUCTANCE MEASUREMENTS.

Figure 4-1 E illustrates the basic bridge circuit for series inductance (LOW Q) measurements at 1KHz. Figure 4-1F illustrates the basic bridge circuit for parallel inductance (HIGH Q) measurements at 1KHz. For series inductance measurements with the FUNCTION switch set to Ls AUTO, the basic bridge circuit is shown in figure 4-1G.

4-10. RANGE AND FUNCTION SWITCH A100.

A. Assembly A100 consists of RANGE switch S101, FUNCTION switch S102, and a printed circuit board for lead and component connections. The RANGE and FUNCTION switches route signals in the instrument for proper operation. RANGE switch S101 selects the resistor which forms one arm of the bridge circuit for balancing during a measurement. The selected resistor correctly attenuates the applied signal. Capacitors C101 through C105 provide frequency compensation for certain ranges when ac voltages are applied during L or C measurements.

b. FUNCTION switch S102 routes signals to and from various functional circuits in the instrument. When set to R position, 40Vdc is routed through S102 and RANGE switch S101 to the unknown R. For L measurements, the bridge arm connections to the DQ and CRL controls are reversed from that for C measurements. This technique maintains the same phase relationship for the bridge error signal and the reference voltage for the AUTO null circuit. The CRL direction indicator lights are also energized for Cp AUTO or Ls AUTO position of the FUNCTION switch. R110 and R111 are fixed bridge resistors selected by FUNCTION switch S102.

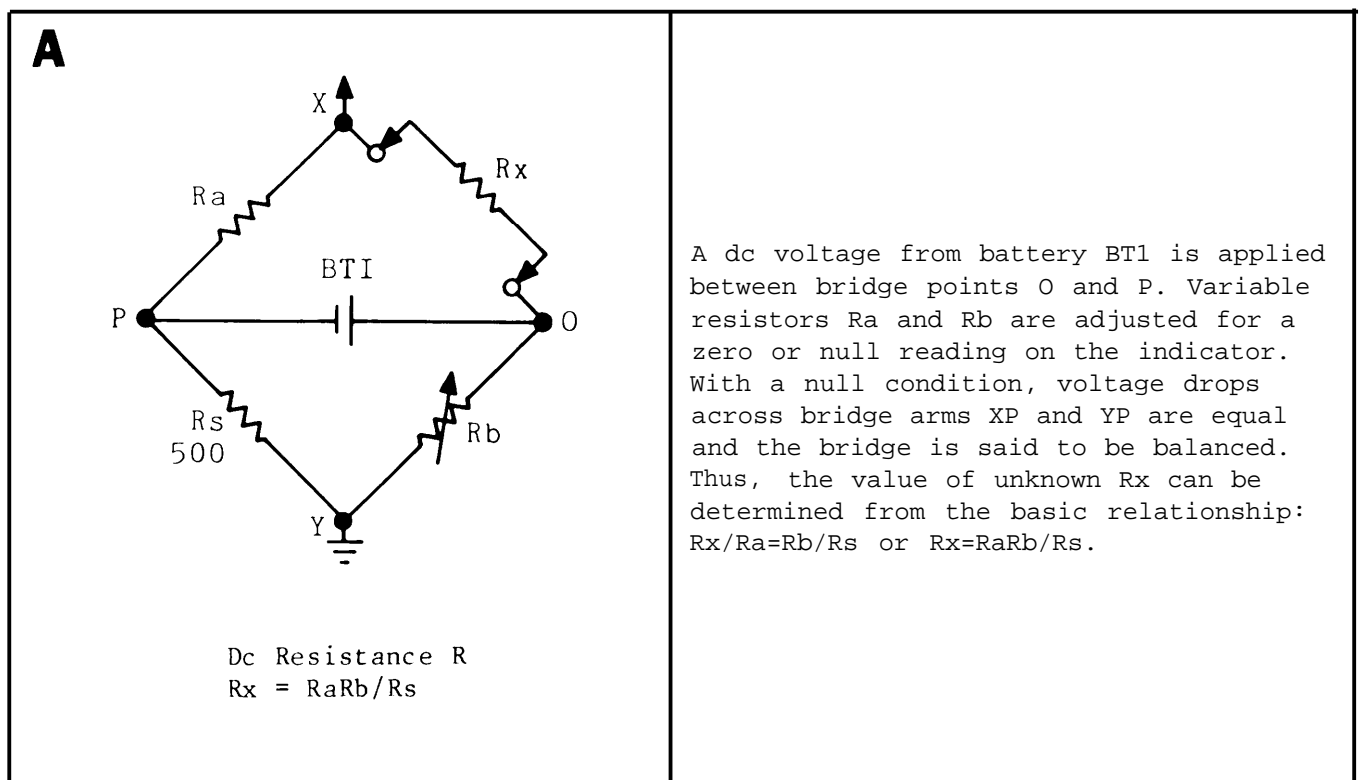
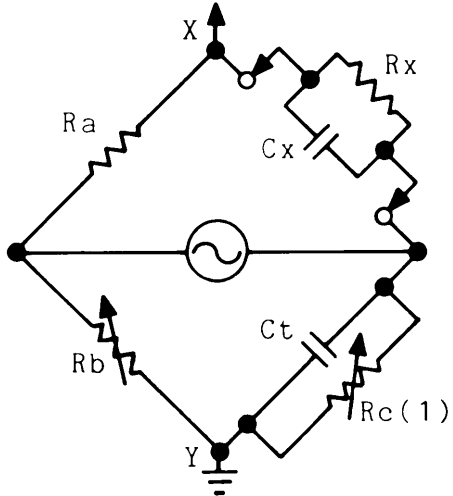

Figure 4-1. Bridge circuit configuration (Sheet 1 of 4).

B



Parallel Capacitance C_p
(HIGH D: 0.05 to 50 at 1kHz)

$$C_x = C_t R_b / R_a$$

$$D_x = \frac{1}{2 f C_x R_x} = \frac{1}{2 f C_t R_c}$$

f = frequency

This circuit is similar to the basic R circuit, but note that capacitor C_t is inserted in parallel with R_c (DQ control). R_x , in parallel with unknown capacitor C_x , represents the inherent resistance of any capacitor. A 1KHZ signal replaces the dc voltage used in R measurements. The relationship for this equivalent bridge circuit are given in B.

C

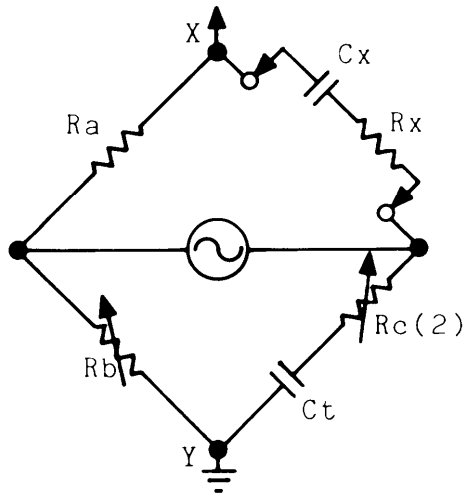

Series Capacitance C_s
(LOW D: 0.001-0.12 at 1kHz)

$$C_x = C_t R_b R_a$$

$$D_x = 2 f C_x R_x = 2 f C_t R_c$$

f = frequency

In this mode, C_t is in series with R_c (DQ control) and loss resistance R_x is in series with unknown capacitor C_x .

Figure 4-1. Bridge circuit configuration (Sheet 2 of 4).

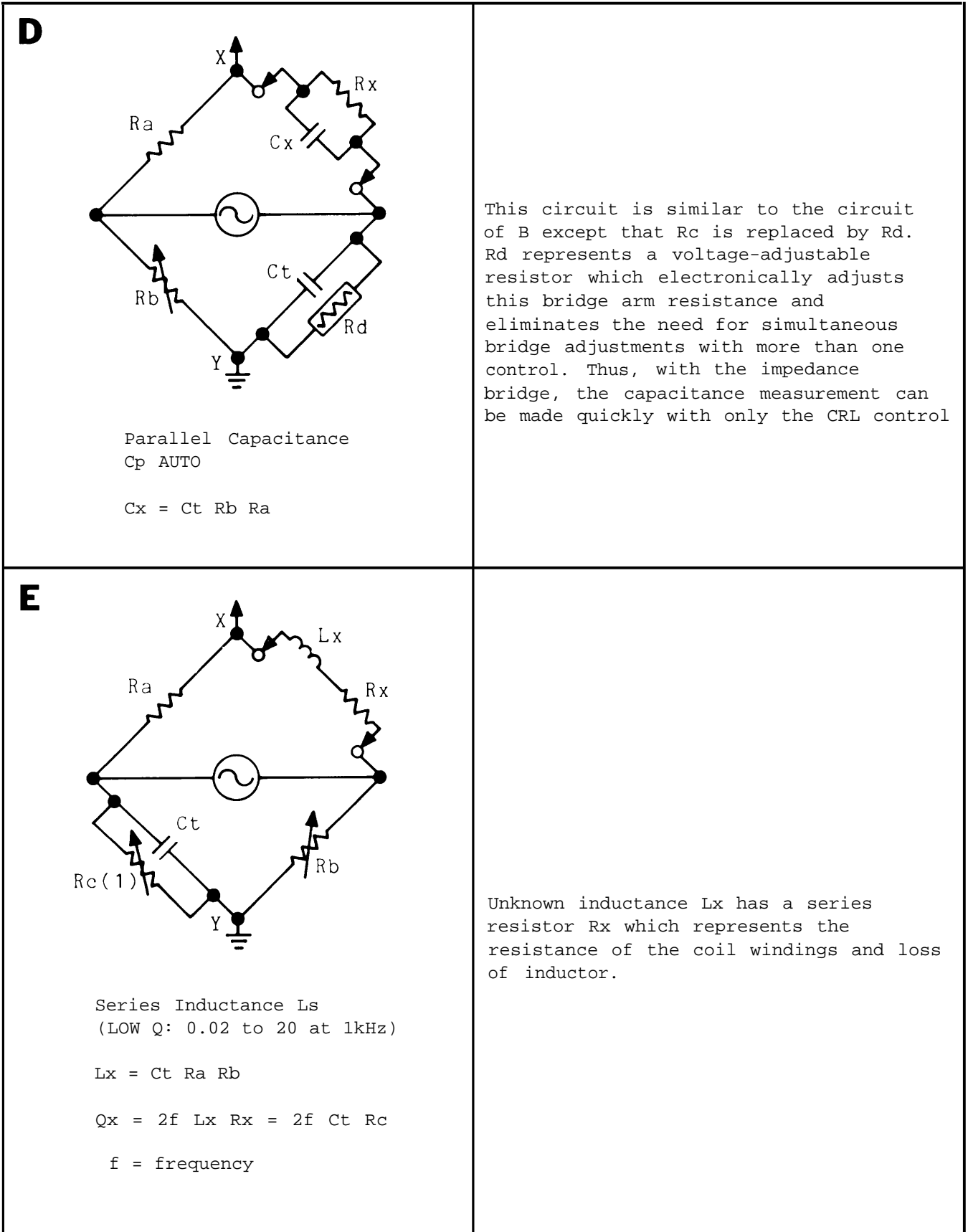
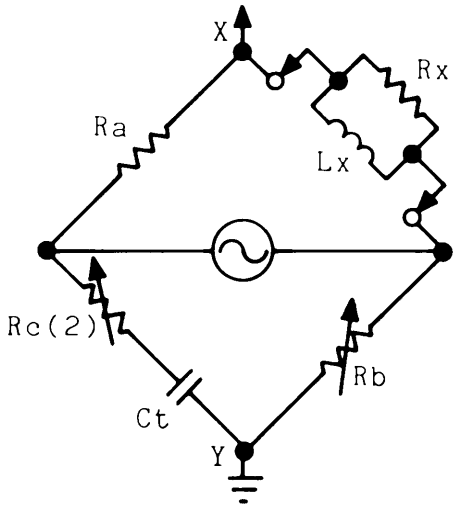

Figure 4-1. Bridge circuit configuration (Sheet 3 of 4).

F



Parallel Inductance Lp
(HIGH Q: 8-1000 at 1kHz)

$$L_x = C_t R_a R_b$$

$$Q_x = \frac{R_x}{2 f L_x} = \frac{1}{2 f C_t R_c}$$

f = frequency

This circuit is similar to the series inductance equivalent circuit, except that loss resistance Rx is in parallel with Lx and Ct is in series with Rc (DQ control).

G

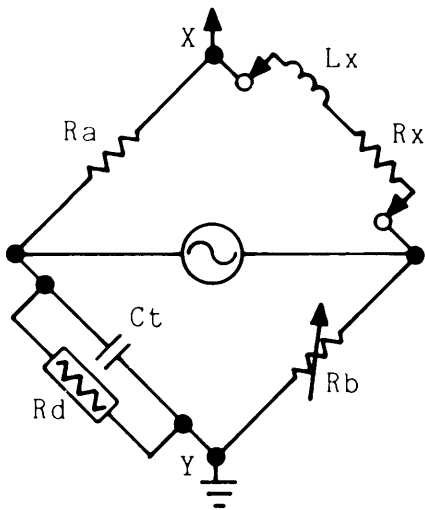

Series Inductance Ls AUTO

$$L_x = C_t R_a R_b$$

This circuit is similar to E except that Rc is replaced by Rd. Rd represents a voltage-adjustable resistor which electronically adjusts this bridge arm resistance and eliminates the need for simultaneous bridge adjustments with more than one control. Thus, with the impedance bridge, the inductance measurement can be made quickly with only the CRL control.

Figure 4-1. Bridge circuit configuration (Sheet 4 of 4).

4-11. POWER SUPPLY AND 1KHz OSCILLATOR A200.

a. Assembly A200 includes four power supply sections which generate operating dc voltages and also a 1KHz oscillator circuit. The +13Vdc and -12Vdc outputs are regulated and the +40Vdc and +110Vdc outputs are not. The oscillator circuit generates the 1KHz signal for driving the instruments bridge circuit during L and C measurements.

b. Primary power as shown in schematic diagram (Fig. FO-3), either 115Vac or 230Vac is applied through fuse F1 and LINE switch S1 to T1 primary. Rear-panel 115/230 switch S2 connects T1 primaries in parallel for 115Vac operation or in series for 230Vac operation.

c. The regulated +13Vdc supply consists of full-wave rectifier CR201, CR202 whose output is smoothed by C201, regulated by Q201, Q202, Q203, and further filtered by C203. Breakdown diode CR203 provides a 12.7 volt reference at Q203 emitter. Output voltage variations are sensed at Q203 base, amplified, and supplied to driver Q202 base. Q202 then controls regulator Q201 to oppose the output voltage change. Resistor R204 across Q201 collector-emitter provides protection for Q201 when the +13Vdc output is overloaded.

d. The regulated -12Vdc supply consists of half-wave rectifier CR204 whose output is smoothed by C204, regulated by Q204, and further filtered by C205. Breakdown diode CR205 provides a 12.7 volt reference at Q204 base. When the output voltage starts to change, this is sensed by regulator Q204 which changes its dynamic resistance to oppose voltage change.

e. The unregulated +40Vdc supply consists of half-wave rectifier CR206 whose output is filtered by the RC combination of R207 and C206. Series resistor R207 limits the output voltage to the UNKNOWN terminals during R measurements.

f. The unregulated +110Vdc supply consists of half-wave rectifier CR207 whose output is filtered by C207. This +110Vdc is supplied via pin P, FUNCTION switch S102, and RANGE switch S101 to the decimal point and direction indicator neons.

g. Transistors Q205, Q206, and associated components form a 1KHz oscillator circuit. Emitter follower Q207 provides the buffered 1KHz output to transformer T2 to drive the bridge circuit for L and C measurements. The oscillator is an RC type with positive feedback from Q206 collector to Q205 base to maintain oscillations. Operating frequency is primarily determined by C209, C210, R208, R209, and R210. Variable resistor R210 permits frequency adjustment. R213 is the output level control. Plus 13Vdc is supplied from pin D via OSCILLATOR INT- EXT switch S3 to pin U. Thus, the oscillator circuit is energized only when S3 is set to INT. Capacitors C208 and C214 filter 1KHz from the +13Vdc line.

4-12. REFERENCE VOLTAGE ASSEMBLY A300.

a. The circuits of assembly A300 receive the 1KHz signal from bridge transformer T2 and generate a negative output pulse. The duration of this pulse is equal to twice the phase angle (θ) between the bridge driving signal from T2 and the 1KHz signal across one arm of the bridge circuit. This 2 θ pulse duration thus represents a phase relationship in part of the bridge circuit and is used to detect the error signal component in phase with the reference voltage of the phase detector. Detector output drives the voltage-controlled resistor automatically for bridge balance. This automatic action occurs-when the FUNCTION switch is set to Cp AUTO or Ls AUTO. The 2 θ relationship is used because it provides maximum null resolution and stability for the loop circuit.

b. The reference phase circuits reconstruct the bridge driving signal from T2 and compose a 1KHz square wave which is in phase with this driving source. This reference square wave is applied to the phase comparator. The reference phase circuits include high-impedance amplifier no. 1 (Q305, Q306), differential amplifier (Q303, Q304), and limiting amplifier Q307.

c. The 1KHz signal from T2 (4) and switch assembly A100 is applied at A300 (9). From pin 9 the signal is ac coupled through C307 to Q306 base. Q306 and Q305 amplify the signal current and apply it to differential amplifier transistor Q304. Capacitor C305 is selected to provide positive feedback to Q306. This compensates input capacitance of the amplifier and stray capacitance of CRL resistor R3. The other input to the differential amplifier is from Q301 emitter, which is the other signal from the bridge circuit. Thus the differentially summed output at Q303 collector is a reconstructed sine wave in phase with the bridge driving signal. From Q303 collector, the sine wave is ac coupled through C309 to Q307 base. Diodes CR301, CR302 limit peaks, so the output from Q307 collector is a square wave. This square wave is ac coupled through C317 to the phase comparator circuit.

d. The variable phase circuits receive an ac voltage from one arm of the bridge circuit and supply a square wave which is out of phase with the bridge driving signal at T2. The variable phase circuits include high-impedance amplifier No. 2 (Q301, Q302) and limiting amplifiers Q308 and Q309.

e. The 1KHz signal from T2 (3) and switching assembly A100 is applied at A300 (7). From pin 7 the signal is ac coupled through C301 to Q301 base. Q301 and Q302 amplify the signal and supply it to limiter amplifier Q308. (From Q301 emitter, the signal is also supplied to Q303 base in the reference phase circuit.) Diodes CR303, CR304 limit signal peaks, so Q309 input is a clipped sine wave. Limiting amplifier Q309 and diodes CR305, CR306 further limit peaks, so Q309 output is a square wave. This square wave is the second input to the phase comparator circuit.

f. Phase comparator Q310, Q311 receives two square wave inputs: 1) one from the reference phase circuits which is in phase with the bridge driving signal, and 2) a second from the variable phase circuits which has a phase relationship 0 with the bridge driving signal. The phase comparator output at Q311 collector is a negative pulse whose duration is equal to phase angle 0.

g. The phase comparator acts as an and gate; that is, when input at Q310 base is positive-going and the reference square wave at Q311 base is negative-going, a negative pulse results at Q311 collector. This negative pulse is 0 wide; that is, its duration is equal to the two phase comparator inputs.

h. The Miller integrator circuit receives the negative pulse from the phase comparator and generates a positive "A" shaped waveform. The duration of the "A" shaped pulse is twice that of the input negative pulse. C318 is the integrating capacitor.

j. Transistor switch Q313 makes a square wave from the "A" shaped input pulse. The square wave output duration is equal to the input pulse duration. Q313 is normally off. When the input pulse starts, Q313 saturates and remains on until the input pulse returns to its base line value. The switched output is supplied at pin 15 to drive the one-shot multivibrator on detector assembly A400.

4-13. DETECTOR ASSEMBLY A400.

a. Assembly A400 circuits receive the bridge unbalance information and the 20 pulse from the reference voltage assembly A300. These inputs are used to automatically adjust a variable resistance circuit which replaces a resistance in one arm of the bridge for Cp AUTO or Ls AUTO functions. In addition, these inputs are used to control the direction indicator lights. The right or left direction light is on, depending on which way the CRL control must be rotated to balance the bridge. Detector circuits include the error signal amplifier, phase detector, one-shot multivibrator, differential amplifier, Miller integrator, variable resistor circuit, and CRL direction light control.

b. The error signal 80dB amplifier includes transistors Q401 through Q405 and associated components. Input at pin 1 is a 1KHz sine wave (if internal oscillator is used ; otherwise frequency of external oscillator) whose amplitude represents the amount of bridge unbalance (error signal). Sine wave outputs from Q404 drive part of the phase detector and also the meter circuit. An output from Q405 emitter (phase shifted 90 DEG leading) drives that part of the phase detector which controls the direction indicator light circuit. Thus, when an unknown L or C is connected across the UNKNOWN terminals, the bridge circuit is unbalanced and an error signal results. This causes a meter reading, a direction light to be on, and also controlled value for the variable resistance.

c. The error signal is applied at pin 1 and amplified by Q401, Q402, and Q403. Diodes CR402 through CR405 provide limiting at Q402 to obtain logarithmic amplifier characteristics. Also, when oscillator switch S3 is set to INT (pins 6 and 7 shorted), negative feedback occurs from Q404 emitter to Q403 base through a twin T filter. The T filter provides minimum negative feedback at 1KHz, which peaks the amplifier at this frequency and it effectively becomes a tuned amplifier with overall loop gain maximum. Breakdown diode CR401 in Q403 emitter establishes the dc operating point for this transistor. Q404 is an emitter follower which supplies the amplified error signal to part of the phase detector. Phase shifting network R420 and C412 cause the output voltage waveform at Q405 emitter to lead the error signal by 90 DEG. Diodes CR406 through CR409 are a full-wave rectifier to provide a dc for the meter which is proportional to bridge unbalance.

d. The one-shot multivibrator (OS MV) receives the negative pulse via pin 12 from switching amplifier Q313 and generates 1 KHZ square waves. Complementary square waves from both collectors of the OS MV are applied to phase detector diodes CR412 and CR413.

e. The quiescent state of the OS MV is Q406 off, Q407 on. RC combination C416, C417, R425 differentiates the positive-going trailing edge of the negative input pulse. The resulting positive pulse at Q406 base turns this transistor on. RC combination R428, C418 determines how long the Q407 off, Q406 on condition exists. Diodes CR410, CR411 provide a speed-up action for the OS MV when it changes states so that the square wave edges are sharpened.

f. The phase detector circuit receives square waves from the OS MV and sine waves from the error signal amplifier. A varying dc output results at R435, R436 junction which is proportional to bridge unbalance. The phase detector is actually two phase detecting circuits: one for the variable resistance circuit, and a second for the CRL direction light control circuit.

g. The error signal sine wave from Q404 emitter is applied through C411 to CR412, CR413 junction. The complementary square waves from the OS MV are applied through R433 and R434 to the ends of these diodes. When Q406 collector is positive (+4.4 volts), and Q407 collector is zero, diodes CR412 and CR413 conduct. Error signal amplifier output voltage appears at R435, R436 junction without attenuation. When Q406 collector voltage is zero and Q407 collector is +4.4 volts, CR412 and CR413 are cut off; error signal amplifier output voltage does not appear at R435, R436 and this junction is the same voltage level as the average voltage level of +2.2 volts. The voltage level at R430, R431 junction is the average level of +2.2 volts. Thus the differential output between R435, R436 junction and R430, R431 junction is the synchronized rectified output of the error signal. This output is supplied to Q408 for proportional control of the variable resistance circuit.

h. Operation of the CR414, CR415 light control section of the phase detector is similar, except that the error signal sine wave is phase shifted 90 DEG ahead by R420, C412, Q405 combination. When the bridge is unbalanced with the CRL counter too low, an error signal is applied and the dc output to the light control differential amplifier is more positive. With the CRL counter too high, output is less positive.

i. The differential amplifier and Miller integrator circuit uses the phase detector output to control the variable resistance circuit. The Miller integrator provides stability for the overall feedback loop near null or bridge balance when most sensitivity is required. The differential amplifier output at Q408 collector is a dc level which changes with the phase detector input at Q408 base. Integrator circuit Q410 and C420 amplifies Q408 output and stabilizes control of the variable resistance circuit. Near null or bridge balance point, noise and random variations are minimized by the integrator circuit.

j. The variable resistance circuit includes +6Vdc regulator Q415, phase splitter Q411, and emitter followers Q412, Q413, Q414. Diodes CR419, CR420 are the heart of the variable resistance circuit, with their bias state controlling their resistance. In Cp or Ls AUTO position, this controlled resistance becomes the R value which replaces the DQ control in one arm of the bridge.

k. Phase splitter Q411 conduction controls CR419, CR420 bias through emitter followers Q412, Q413 and Q414. When Q411 base voltage decreases, current through R446 and R447 decreases; base voltage levels of Q412 and Q413 increases. This causes the effective resistance of the diodes to become smaller. When Q411 input voltage causes Q411 to be cut off, current begins to flow through CR416, CR417, and CR418; base voltage level of Q412 and Q413 cannot increase. At this time, diodes CR419, CR420 have the minimum resistance for the bridge arm. When Q411 base voltage increases, Q411 turns on and Q411 collector to emitter voltage becomes small. Diodes CR419, CR420 are cut off and their effective resistance becomes several hundred megohms. Thus, the variable resistance circuit changes its resistance as controlled by bridge balance information from the phase detector.

l. The differential amplifier and lamp driver circuit uses information from the phase detector circuit to light the correct CRL direction lamp. Foldout 1 is a simplified diagram of the light control circuit. The error dc level at Q416 base is added with the reference level at Q417 base by the differential amplifier to give a resulting dc level at driver Q418 base. When the CRL control is set to low for bridge balance, Q416 is turned on; this causes Q418 to be off with its collector voltage rising to near +110 volts, and right CRL light V602 is energized through R456. With the CRL control too high, Q416 is off, Q418 is on, and left CRL light V601 is energized through R457, Q418, and R455.

4-14. CHASSIS ASSEMBLY A500.

Chassis assembly A500 consists of the main mounting plate (top deck and rear panel) and those parts that are permanently riveted on it. These parts are identified as: J1, ac power jack; J2 18-pin connector for printed circuit card assembly A200; J3 15-pin connector for printed circuit card assembly A300; J4 15-pin connector for printed circuit card assembly A400; and S2 115/230 volt ac power slide switch .

4-15. DECIMAL POINT AND DIRECTION INDICATOR LAMP A600.

This assembly includes decimal point neons V603, V604, V605, series resistors R601 and CRL direction neons V601, V602. Decimal point lights are controlled by the position of the RANGE and FUNCTION switches.

SECTION IV. PREVENTIVE MAINTENANCE CHECKS AND SERVICES

4-16. GENERAL.

This section contains the general support maintenance, preventive maintenance checks and services procedures required to insure that the equipment will perform its designated function until the next scheduled service. To insure that the equipment is always ready for operation, it must be inspected systematically so that defects may be discovered and corrected before they result in serious damage or failure.

4-17. CORROSION PREVENTION.

Remove rust and corrosion from metal surfaces by lightly sanding with fine sandpaper or emery cloth. Sand the area down to the bare metal and feather the edges to obtain a smooth surface. Brush or spray two coats of paint (let the paint dry between each coat) on the sanded area to protect it from further rust and corrosion. Refer to the applicable instructions specified in TB 746-10 for more detailed information on cleaning and refinishing army equipment.

Table 4-1. General support PMCS.

ITEM NO .	INTERVAL						ITEM TO BE INSPECTED	PROCEDURES
	W	M	Q	S	A	B		
1			X				ZM-71A/U performance tests CAPACITANCE MEASUREMENT CHECK	Before proceeding with any tests or adjustments, set up the ZM-71A/U as shown in chapter 2, section 111. Remove top, bottom, and side covers on the impedance bridge. 1. For this test the following components are needed: One each; 1uF, 0.1uF, 0.01uF, 1000pF, 100pF, 10PF, and 1pF standard capacitors. One each; 7.5 ohm, 30 ohm, 1500hm, 30K ohm, 15K ohm, 3K ohm, 1.5K ohm, 300 ohm, and 78.7 ohm resistor's. 2. Perform the turn-on procedures listed in paragraph 2-3 and 2-4. 3. Set the FUNCTION switch to Cp AUTO. 4. Connect the 1uF standard capacitor to the UNKNOWN terminals. 5. Set the RANGE switch to the nF position to light the right decimal point. 6. Rotate the SENSITIVITY control fully clockwise. 7. Rotate the CRL control the direction shown by the direction indicator until a null is indicated on the meter. Direction lights should change at the null position.

Table 4-1. General support PMCS (Continued).

ITEM NO.	INTERVAL						ITEM TO BE INSPECTED	PROCEDURES
	W	M	Q	S	A	B		
								8. Set the FUNCTION switch to Cs LOW D. 9. Adjust the DQ dial for a null on the meter. (Slight adjustment of the CRL control will help null the meter). 10. Read the values of C on the numerical counter and D on the DQ dial. These readings should be within the values listed below. 11. Repeat steps 2 thru 10 using the other standard capacitors listed. When required, connect the resistors in series with the standard capacitors being measured, or in parallel with the standard capacitors being measured.

STD. CAP. VALUE	CONNECT RESISTOR FOR D	C READINGS IN Cp-AUTO	FUNCTION	C READINGS ON CRL COUNTER	D READINGS ON DQ DIAL
1uF		0984 -1016 nF	Cs	3989 - 1011 nF	less than 0.002
0.1uF		098.4-101.6 nF	Cs	398.9 - 101.1 nF	less than 0.002
0.1uF	S 7.5 ohm	098.4-101.6 nF	Cs	398.9 - 101.1 nF	0.0024 - 0.007
0.1uF	S 30 ohm	098.4-101.6 nF	Cs	398.9 - 101.1 nF	0.0159 - 0.022
0.1uF	S 150 ohm	097.5-100.7 nF	Cs	098.9 - 101.1 nF	0.088 - 0.099
0.1uF	P 30K ohm	098.4-101.6 nF	Cp	098.9 - 101.1 nF	0.056 - 0.05
0.1uF	P 15K ohm	098.4-101.6 nF	Cp	098.9 - 101.1 nF	0.112 - 0.1
0.1uF	P 3K ohm	098.4-101.6 nF	Cp	098.9 - 101.1 nF	0.575 - 0.49
0.1uF	P 1.5K ohm	098.4-101.6 nF	Cp	098.9 - 101.1 nF	1.2 - 0.95
0.1uF	P 300 ohm		Cp	098.9 - 101.1 nF	10 - 4
0.1uF	P 78.7 ohm		Cp	098.9 - 101.1 nF	10.6 - 50
0.01uFF		09.84-10.16 uF	Cs	09.89 - 10.11 nF	less than 0.002
1000pF		0974 -1026 pF	Cs	0979 - 1021 pF	less than 0.002
100pF		0097 -0103 pF*	Cs	0097 - 0103 pF*	less than 0.002
10pF		0009 -0011 pF*	Cs	0009 - 0011 pF*	
1pF		0000 -0002 pF*	Cs	0000 - 0002 pF*	

* Subtract residual capacitance from measured value.
 When connecting resistor for standard D value, S is series, P is parallel.

INDUCTANCE MEASUREMENT CHECK	PROCEDURES
	1. For this test the following components are needed: One each; 1mH, 10mH, and 100mH standard inductors. 2. Perform the turn-on procedures listed in paragraph 2-3 and 2-4. 3. Set the FUNCTION switch to Lp AUTO.

Table 4-1. General support PMCS (Continued).

ITEM NO .	INTERVAL						ITEM TO BE INSPECTED	PROCEDURES
	W	M	Q	S	A	B		
							<ol style="list-style-type: none"> 4. Connect the 1mH standard inductor to the Unknown terminals. 5. Set the RANGE switch to the uH position to light the right decimal point. 6. Rotate the SENSITIVITY control fully clockwise. 7. Rotate the CRL control the direction shown by the direction indicator until a null is indicated on the meter. Direction lights should change at the null position. 8. Set the FUNCTION switch to Ls LOW Q, or Lp HIGH Q. 9. Adjust the DQ dial for a null on the meter. (Slight adjustment of the CRL control will help null the meter). 10. Read the values of L on the numerical counter and D on the DQ dial. These readings should be within the values listed below. 11. Repeat steps 2 thru 10 using the other standard inductors listed. 	

STD. INDUCTOR VALUE	L READINGS IN Ls AUTO	FUNCTION	L READINGS ON CRL COUNTER	Q READINGS ON DQ DIAL
1 mH	0974 - 1026 uH	Ls	0979 - 1021 uH	-
10 mH	09.84-10.16 mH	Ls	09.89 - 10.11 mH	-
100 mH	098.4-101.6 mH	Ls	098.9 - 101.1 mH	-

INTERVAL	ITEM TO BE INSPECTED	PROCEDURES
	RESISTANCE MEASUREMENT CHECK	<ol style="list-style-type: none"> 1. For this test the following components are needed: One each; 10Mohm, 1Mohm, 100Kohm, 7.Kohm, 5Kohm, 2Kohm, 1Kohm, 100 ohm, 10 ohm, and 1 ohm 0.250 watt, 0.05%, fixed film or wirewound resistors. 2. Connect the test equipment as shown. Remove the shorting strap on the voltmeter common/ground terminal to isolate it from ground. Connect the voltmeter common/ground/low terminal to the impedance bridge detector terminal (back panel) ground. Connect the voltmeter input lead to the unknown low terminal on the impedance bridge.

Table 4-1. General support PMCS (Continued).

ITEM NO.	INTERVAL						ITEM TO BE INSPECTED	PROCEDURES																								
	W	M	Q	S	A	B																										
								<ol style="list-style-type: none"> 3. Perform the turn-on procedures listed in paragraph 2-3 and 2-4. 4. Set the FUNCTION switch to R. 5. Connect the 10Mohm resistor to the UNKNOWN terminals. 6. Rotate the SENSITIVITY control to deflect the null meter two scales from null. 7. Set the RANGE switch to indicate the lesser deflection on the null meter. 8. Rotate the SENSITIVITY control fully clockwise. 9. Rotate the CRL control for a null indication on the meter, noting the position of the decimal point, and the range/function window. 10. Read the value of R on the numerical counter. These readings should be within the values listed below. 11. Repeat steps 3 thru 10 using the other standard resistors listed. <table border="0" style="margin-left: 40px;"> <thead> <tr> <th style="text-align: left;">STD. RESISTOR VALUE (OHMS)</th> <th style="text-align: left;">R READINGS ON CRL COUNTER</th> </tr> </thead> <tbody> <tr> <td>10,000,000</td> <td>0.979- - 10.21 M ohms</td> </tr> <tr> <td>1,000,000</td> <td>0989 - 1011 K ohms</td> </tr> <tr> <td>100,000</td> <td>098.9 - 101.1 K ohms</td> </tr> <tr> <td>10,000</td> <td>09.89 - 10.11 K ohms</td> </tr> <tr> <td>7,500</td> <td>07.42 - 07.58 K ohms</td> </tr> <tr> <td>5,000</td> <td>04.94 - 05.06 K ohms</td> </tr> <tr> <td>2,000</td> <td>01.97 - 02.03 K ohms</td> </tr> <tr> <td>1,000</td> <td>0989 - 1011 ohms</td> </tr> <tr> <td>100</td> <td>098.9 - 101.1 ohms</td> </tr> <tr> <td>10</td> <td>09.79 - 10.21 ohms</td> </tr> <tr> <td>1</td> <td>00.97 - 01.03 ohms</td> </tr> </tbody> </table> <ol style="list-style-type: none"> 1. Connect the test equipment as shown. 2. Set the Voltmeter to measure 40 Vdc. 3. Perform the turn-on procedures listed in paragraph 2-3 and 2-4. 4. Set the FUNCTION switch to R. 5. Set the RANGE switch fully counterclockwise . 6. Voltmeter should indicate 30 to 40Vdc. 	STD. RESISTOR VALUE (OHMS)	R READINGS ON CRL COUNTER	10,000,000	0.979- - 10.21 M ohms	1,000,000	0989 - 1011 K ohms	100,000	098.9 - 101.1 K ohms	10,000	09.89 - 10.11 K ohms	7,500	07.42 - 07.58 K ohms	5,000	04.94 - 05.06 K ohms	2,000	01.97 - 02.03 K ohms	1,000	0989 - 1011 ohms	100	098.9 - 101.1 ohms	10	09.79 - 10.21 ohms	1	00.97 - 01.03 ohms
STD. RESISTOR VALUE (OHMS)	R READINGS ON CRL COUNTER																															
10,000,000	0.979- - 10.21 M ohms																															
1,000,000	0989 - 1011 K ohms																															
100,000	098.9 - 101.1 K ohms																															
10,000	09.89 - 10.11 K ohms																															
7,500	07.42 - 07.58 K ohms																															
5,000	04.94 - 05.06 K ohms																															
2,000	01.97 - 02.03 K ohms																															
1,000	0989 - 1011 ohms																															
100	098.9 - 101.1 ohms																															
10	09.79 - 10.21 ohms																															
1	00.97 - 01.03 ohms																															

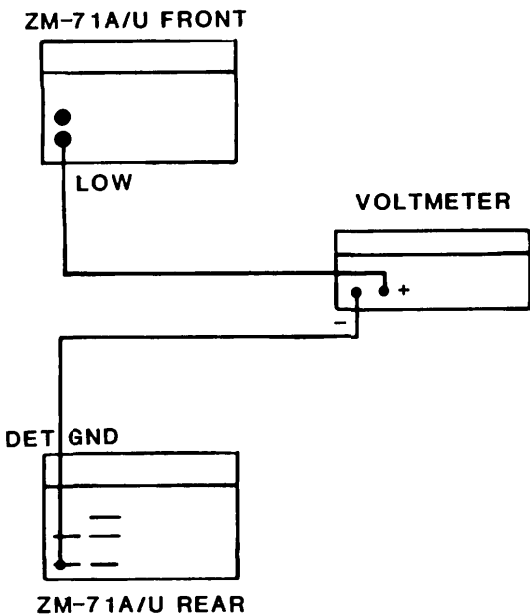
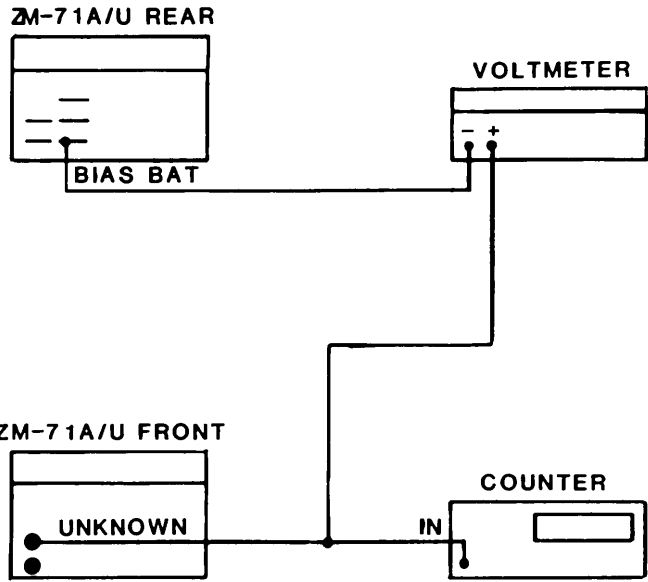
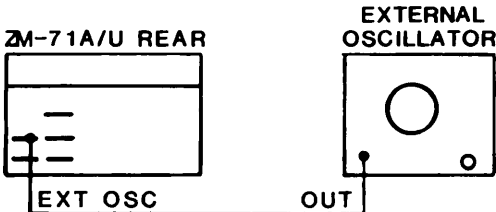

Table 4-1. General support PMCS (Continued).

ITEM NO.	INTERVAL						ITEM TO BE INSPECTED	PROCEDURES
	W	M	Q	S	A	B		
							INTERNAL OSCILLATOR CHECK.	<ol style="list-style-type: none"> 1. Connect the test equipment as shown. 2. Set the Voltmeter to measure 120mV. 3. Set the Frequency Counter to measure 1,000 Hz. 4. Perform the turn-on procedures listed in paragraph 2-3 and 2-4. 5. Set the FUNCTION switch to Ls LOW Q. 6. Set the DQ control fully counterclockwise. 7. Voltmeter should indicate 80 to 120 mV rms. 8. Frequency Counter should indicate 980 Hz to 1020 Hz.
							BRIDGE CAPACITOR C1 CHECK.	 <ol style="list-style-type: none"> 1. Connect the test equipment as shown. 2. Set the ZM-71A/U controls as follows: FUNCTION CS LOWD RANGE switch nF with middle decimal on XXX.X CRL counter 1000 SENSITIVITY fully clockwise INT/EXT EXT DQ VERNIER. CAL Power switch ON 3. Set the external oscillator controls as follows : Frequency 1000Hz Voltage 1Vpp Power switch ON 4. Connect a 0.1uF standard capacitor with a 16 ohm PORM 5%, 0.25W fixed resistor in parallel to the UNKNOWN terminals. 5. Balance the bridge (null) with the CRL control. 6. The CRL counter should read PORM 0.3% (For example above 99,7 to 100.3 nF). 

SECTION V. TROUBLESHOOTING

4-18. TROUBLESHOOTING TECHNIQUES.

Troubleshooting the Impedance Bridge ZM-71A/U has been simplified considerably through the use of circuit card assemblies which contain the major portion of the electronics required for operation. Although there are many malfunctions that might occur in the Impedance Bridge ZM-71A/U, isolating the malfunction to the probable cause is relatively simple. When a malfunction occurs, the easiest way to isolate the problem caused is by using operation procedures in chapter 2, section III, to identify the problem. After the problem has been properly identified, the table can be used for locating the malfunction in the troubleshooting table. The troubleshooting table (table 4-3) lists the malfunction, probable cause, and corrective action.

Problems with the equipment not caused by a component failure or not correctable using the troubleshooting procedures will most likely be the result of a bad or broken connection, broken wiring, shorted wiring, improperly functioning switch, etc. These problems can be isolated using the schematic diagrams (foldouts 2 through 5) and/or wiring diagram (figure 4-2). Some problems can be directly attributed to improper adjustments. Paragraphs 4-25 thru 4-32 list the adjustments required for the impedance bridge.

4-19. OPERATION PROCEDURES TO TROUBLESHOOTING TABLE CROSS-REFERENCE.

Table 4-2 is used to tie the operation procedures in chapter 2, section III to the troubleshooting procedures in table 4-3. The first column of table 4-2 lists the paragraph number from the operating procedures cross-referenced to the appropriate troubleshooting information in table 4-3.

4-20. TROUBLESHOOTING.

a. General. Table 4-3 has been designed to be used in conjunction with the operating procedures in chapter 2, section III. If the problem cannot be quickly identified and corrected, the repairman should go through the operating procedures step-by-step to identify the problem(s). Because the various circuits of the Impedance Bridge ZM-71A/U are interdependent on one another for proper operation, each problem encountered in the operational check should be corrected before continuing.

b. Arrangement. Table 4-3 lists most problems that might occur in the Impedance Bridge ZM-71A/U along with the probable cause of the problem and the corrective action that should correct the problem. The items listed in the probable cause column are presented in a sequence from the easiest to check and correct to the most difficult and time-consuming to check and correct, taking into consideration the failure probability of the item. The corrective action column gives a brief statement as to the proper corrective action to be taken to correct the problem with appropriate references to disassembly, repair, reassembly, and adjustment instructions where required.

4-21. IMPEDANCE BRIDGE TROUBLESHOOTING CONDITIONS.

a. Before troubleshooting, set the impedance bridge controls as specified in chapter 2, section III, paragraph 2.3.

Table 4-2. Operating Procedures to Troubleshooting
Table Cross Reference

PARAGRAPH NUMBER	PROBLEM	TABLE 4-3 ITEM NUMBER
2-4a	Meter mechanical zero.	1
2-4b	Decimal lamp	2
2-6	Resistance measurements	3,5
2-9	Capacitance measurements	4,6,7
2-11	Capacitor dissipation factor	9,10
2-13	Inductance measurements	4,6,7
2-15	Inductance quality factor	9,10

Table 4-3 Troubleshooting Procedures

ITEM NUMBER	MALUFUNCTION	PROBABLE CAUSE	CORRECTIVE ACTION
1	Mechanical meter adjust does not zero meter.	Defective meter M1.	Replace M1 (paragraph 4-33).
2	Decimal lamps do not light.	Defective fuse F1. Defective A600. Defective A200. Defective A100.	Check/replace F1. Check/replace A600 (paragraph 4-29). Troubleshoot A200 (CR207 circuit figure 4-4). Replace A200 (paragraph 4-26). Troubleshoot A100 (Switch contacts figure 4-3). Replace A100 (paragraph 4-25).
3	Null meter does not deflect for R measurements.	Defective meter M1. Defective CR1/CR2. Defective A200. Defective A100. Defective A700 (resistor R3)	Replace M1 (paragraph 4-33). Check/replace CR1/CR2. Troubleshoot A200 (CR206 circuit figure 4-4). Replace A200 (paragraph 4-26). Troubleshoot A100 (Switch contacts and R110 figure 4-3). Replace A100 (paragraph 4-25). Replace A700 (paragraph 4-30).
4	Null meter does not deflect for C and L measurements.	Defective A200. Defective A400. Defective A100 Defective switch S3. Defective capacitor C1.	Troubleshoot A200 (1KHz oscillator circuit Q205 to Q207 figure 4-4). Replace A200 (paragraph 4-26). Troubleshoot A400 (Error signal amplifier circuit Q401 to Q405 figure 4-6). Replace A400 (paragraph 4-28). Troubleshoot A100 (Switch contacts figure 4-3). Replace A100 (paragraph 4-25). Check/replace S3 (paragraph 4-33). Check/replace C1.

TABLE 4-3 Troubleshooting Procedures (Continued)

ITEM NUMBER	MALFUNCTION	PROBABLE CAUSE	CORRECTIVE ACTION
4	(Continued)	Defective A700 (resistor R3) Defective resistor R4. Defective A900 (resistor R5)	Replace A700 (paragraph 4-30). Replace R4 (paragraph 4-33). Replace A900 (paragraph 4-31).
5	Noisy or no null obtained for R measurements.	Defective A100. Defective A700 (resistor R3)	Troubleshoot A100 (Switch contacts and bridge circuit R101 thru R110, C101 thru C105 figure 4-3). Replace A100 (paragraph 4-25). Replace A700 (paragraph 4-30).
6	Noisy or no null obtained for C or L measurements in Cs, Cp, Ls, and Lp.	Defective A100. Defective A400. Defective A300.	Troubleshoot A100 (Switch contacts and bridge circuit R101 thru R109, R111, C101 thru C105 figure 4-3). Replace A100 (paragraph 4-25). Troubleshoot A400 (Error signal amplifier circuit Q401 to Q405 figure 4-6). Replace A400 (paragraph 4-28). Troubleshoot A300 (High impedance circuit Q301, Q302, Q305, and Q306 figure 4-5). Replace A300 (paragraph 4-27).
7	Noisy or no null obtained for C and L measurements in C and L AUTO.	Defective A100. Defective A300.	Troubleshoot A100 (Switch contacts figure 4-3). Replace A100 (paragraph 4-25). Troubleshoot A300 (Auto null circuit figure 4-5). Replace A300 (paragraph 4-27).
8	Abnormal operation of direction indicator.	Defective A100	Troubleshoot A100 (Switch contacts figure 4-3).

Table 4-3 Troubleshooting Procedures (Continued)

ITEM NUMBER	MALFUNCTION	PROBABLE CAUSE	CORRECTIVE ACTION
8	(Continued)	Defective switch S3. Defective A400.	Replace A100 (paragraph 4-25). Check/replace S3 (pararaph 4-33). Troubleshoot A400 (Neon lamp driver Q418, Differential amp Q416/Q417, phase detector CR414/CR415, or error signal amplifier Q405 figure 4-6). Replace A400 (paragraph 4-28).
9	CRL counter and/or DQ dial not within specifications in Cs, Cp, Ls, and Lp.	Defective A100. Defective A700 (resistor R3) Defective resistor R4. Defective A900 (resistor R5) Defective resistor R6. Defective capacitor C1 Defective capacitor C2 Defective capacitor C3 Defective A300.	Troubleshoot A100 (Switch contacts and bridge circuit R101 thru R111, C101 thru C105 figure 4-3). Replace A100 (paragraph 4-25). Replace A700 (paragraph 4-30). Replace R4 (paragraph 4-33). Replace A900 (paragraph 4-31). Replace R6. Replace C1. Replace C2. Replace C3 (paragraph 4-32). Troubleshoot A300 (High impedance circuit Q301, Q302, Q305, and Q306 figure 4-5). Replace A300 (paragraph 4-27).
10	CRL counter and DQ dial not within specifications in C and L AUTO.	Defective A400.	Troubleshoot A400 (Variable resistance circuit Q411 to Q414, CR416 to CR420, C421 and L401 figure 4-6). Replace A400 (paragraph 4-28).

4-22. VOLTAGE AND WAVEFORMS.

- a. The following are correct pin numbers for the range and function switch assembly (A100).

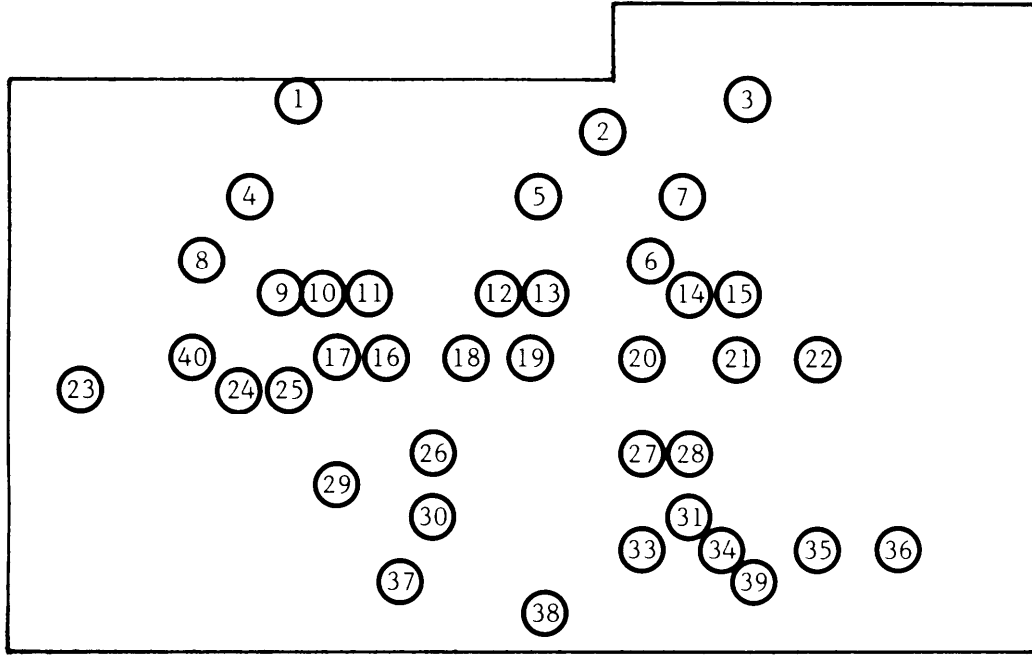

- b. The following are correct test voltages and waveforms for the power supply and 1KHz oscillator circuit card assembly (A200), from the test point (TP) numbers:

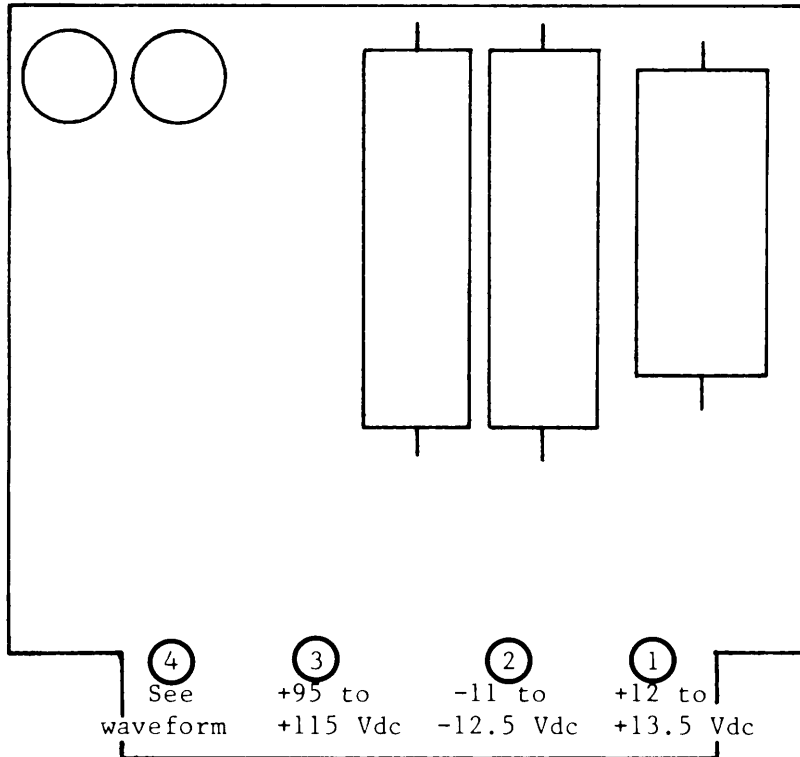

- c. The following are correct test voltages and waveforms for the reference voltage assembly (A300), from the test point (TP) numbers:

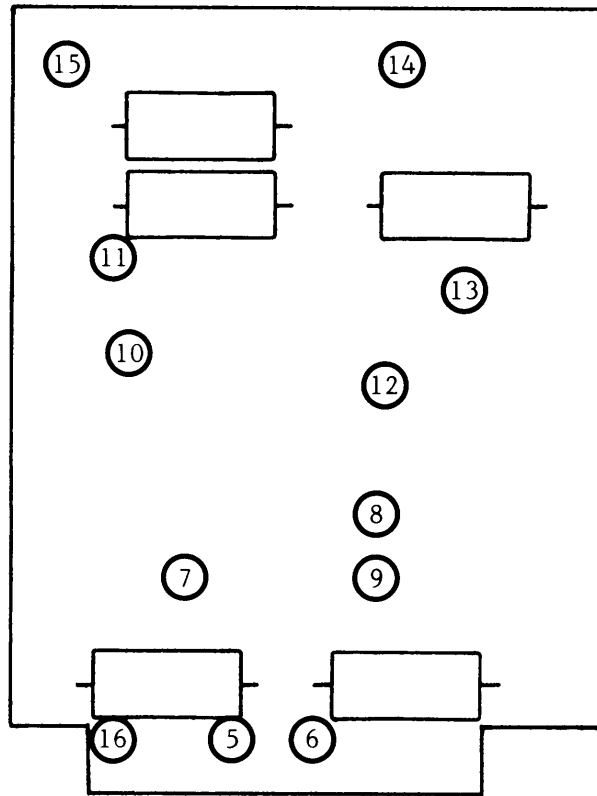

See waveforms for all test points.

d. The following are correct test voltages and waveforms for the detector circuit card assembly (A400), from the test point (TP) numbers:

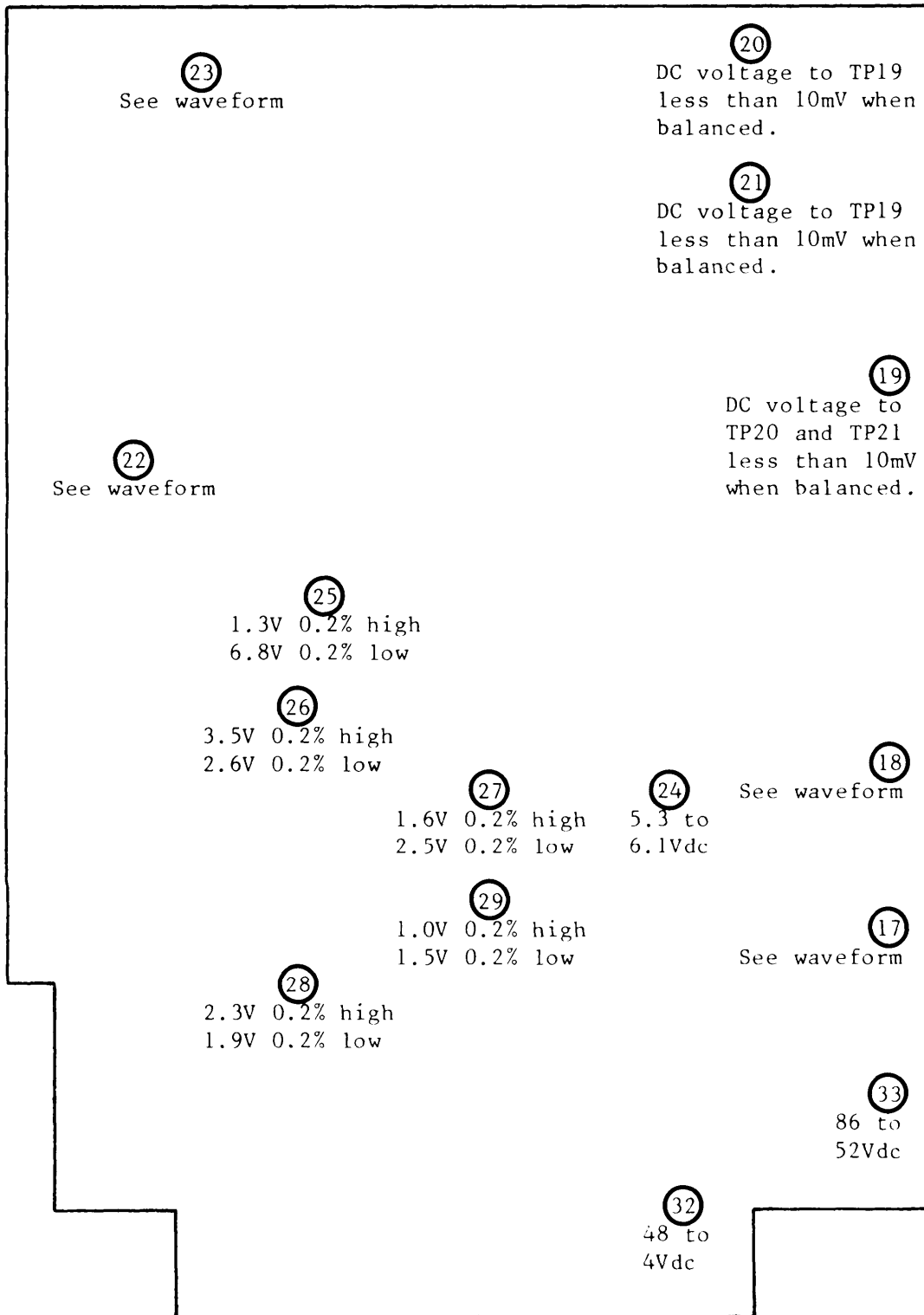

WAVEFORMS

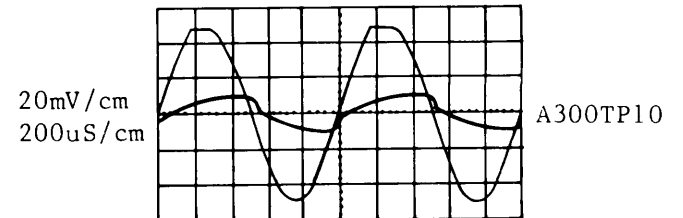
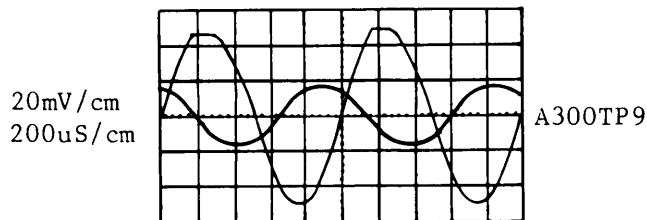
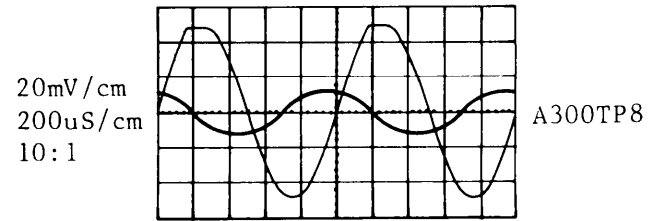
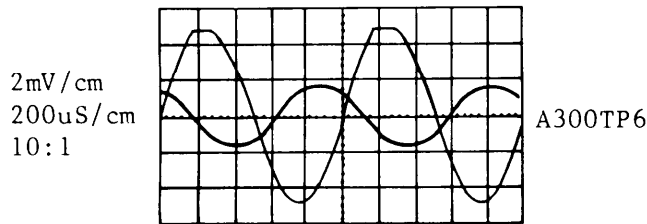
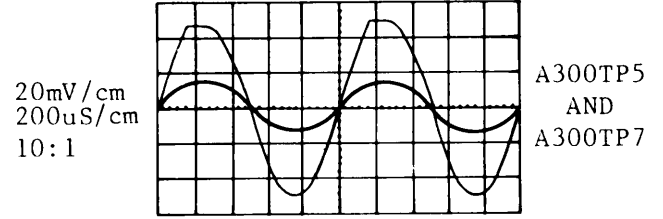
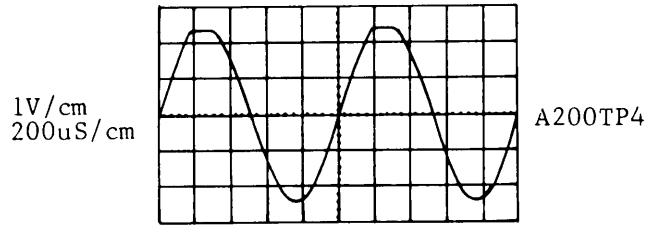

WAVEFORMS (CONTINUED)

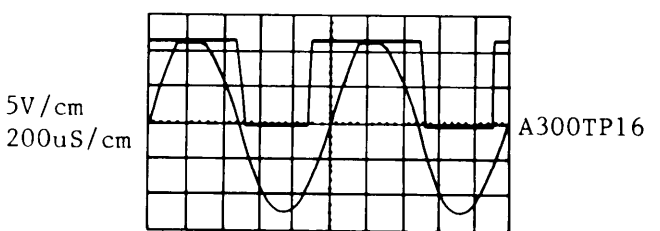
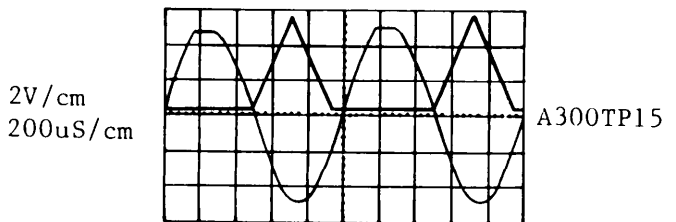
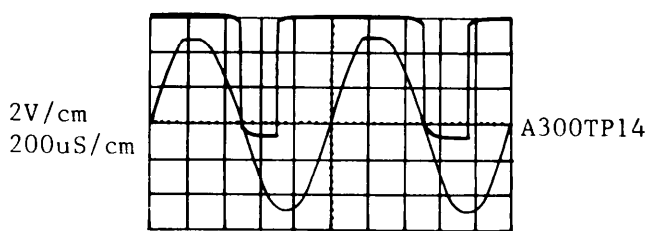
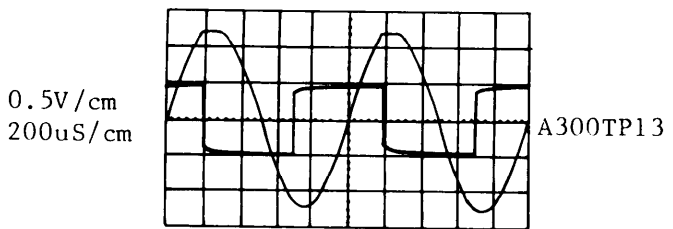
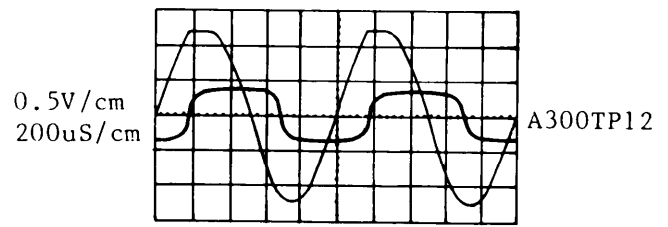
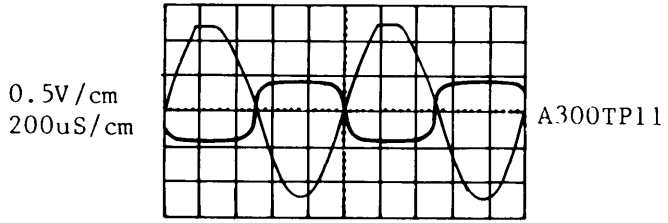

WAVE FORMS (CONTINUED)

2V/cm
200uS/cm

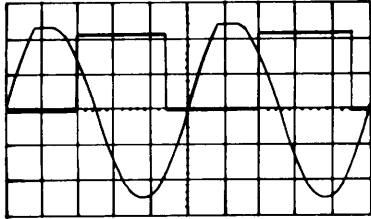

A400TP17

2V/cm
200uS/cm

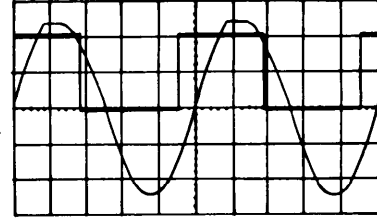

A400TP18

0.1cm
200uS/cm

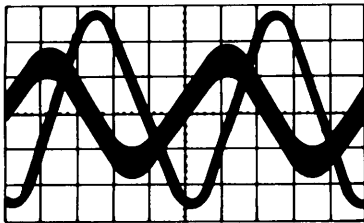

A400TP22A

0.1V/cm
200uS/cm

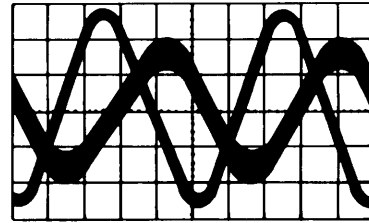

A400TP22B

0.1V/cm
200uS/cm

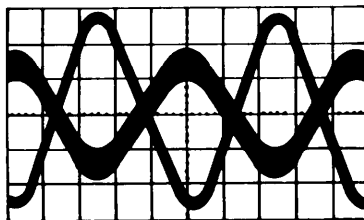

A400TP23A

0.1V/cm
200uS/cm

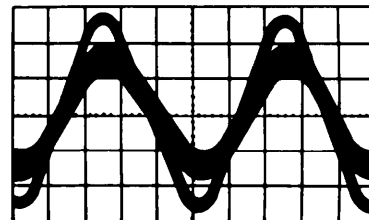

A400TP23B

SECTION VI. MAINTENANCE PROCEDURES

4-23. SCHEMATIC DIAGRAMS.

Foldout 2 is a schematic diagram for the RANGE and FUNCTION switch A100 and the decimal point and direction light A600, foldout 3 is a schematic for the power supply and 1KHz oscillator, foldout 4 is a schematic for the reference voltage assembly A300, and foldout 5 is a schematic diagram for the detector assembly A400. All foldouts are located in the back of this manual.

4-24. WIRING DIAGRAM.

The wiring diagram is to be used in conjunction with the wire list. Each electrical/electronic component of the Impedance Bridge ZM-71A/U is shown on the wiring diagram with its reference designator and all terminals numbered consecutively. The combination of the reference designator and terminal number can be located on the wire list which gives point-to-point connections for each wire, the wire color code, and the wire size.

The wiring diagram for the impedance bridge is shown in figure 4-2 and the wire list is shown in table 4-4.



WARNING

BEFORE BEGINNING MAINTENANCE, ALWAYS UNPLUG THE EQUIPMENT. WITH THE POWER SWITCH TURNED OFF AND THE EQUIPMENT PLUGGED IN, VOLTAGE IS STILL PRESENT IN CERTAIN PLACES.

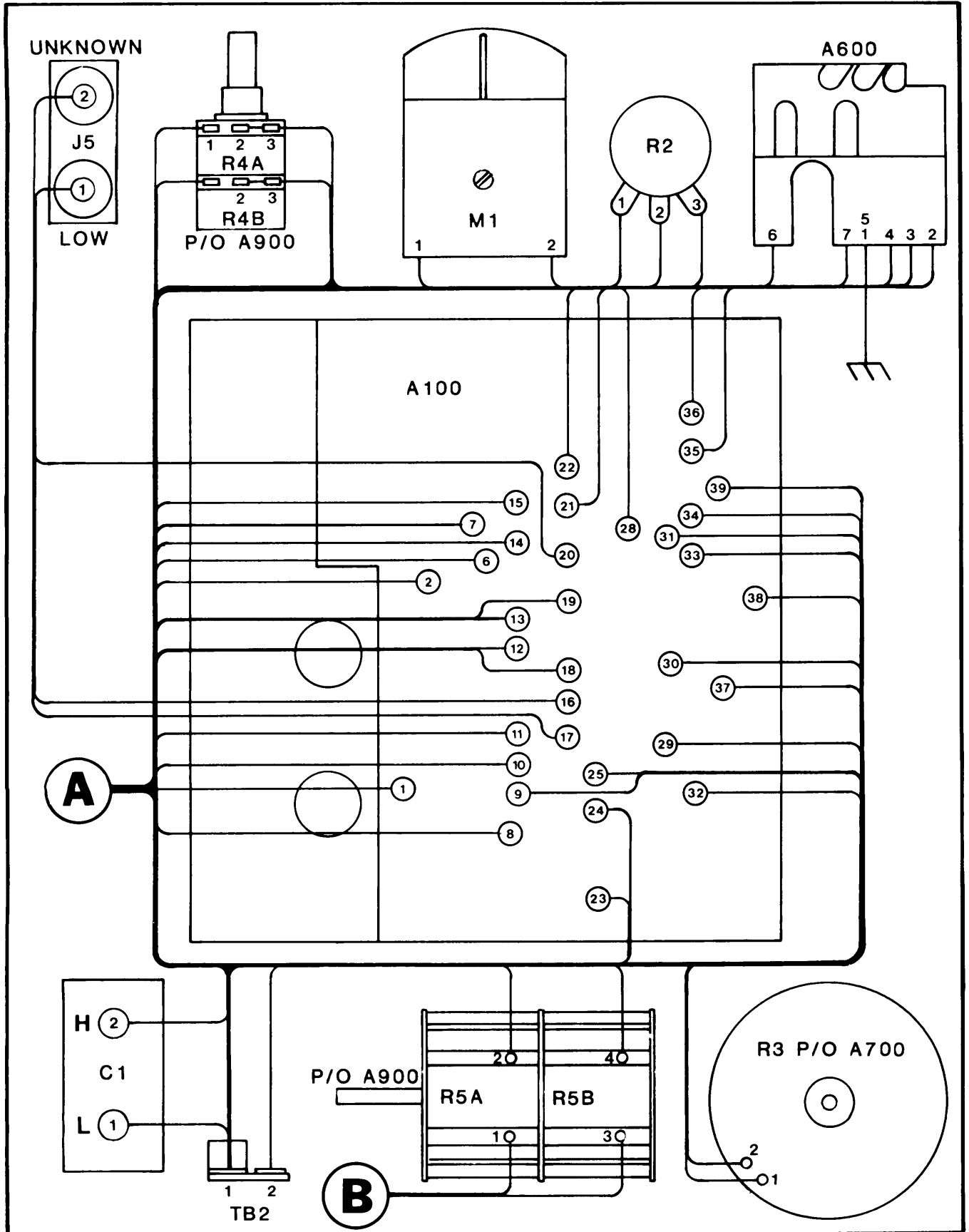

Figure 4-2. Impedance Bridge Wiring Diagram (Sheet 1 of 2).

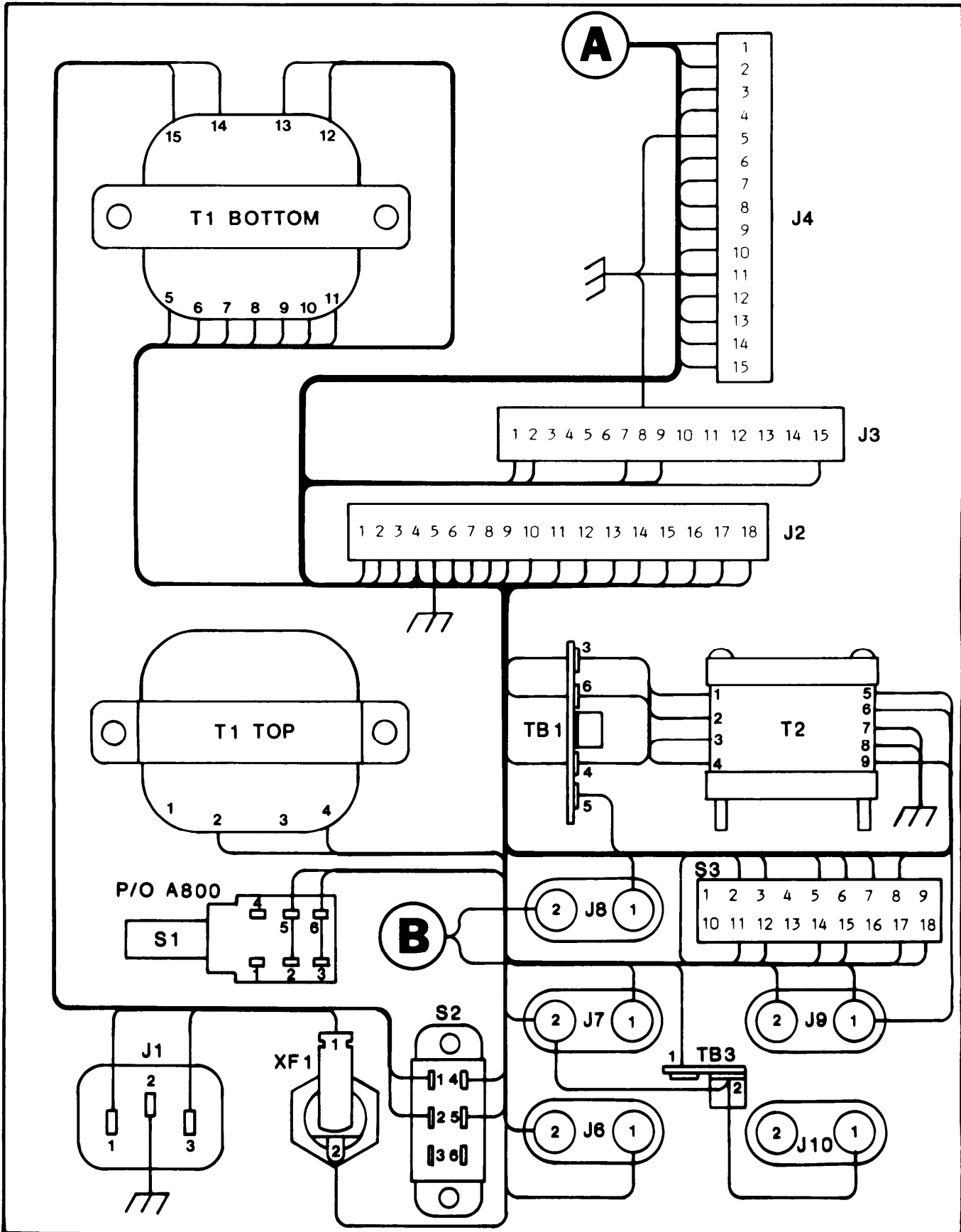

Figure 4-2. Impedance Bridge wiring Diagram (Sheet 2 of 2).

Table 4-4. ZM-71A/U Wire List

FROM	TO	COLOR CODE	WIRE SIZE
A100-1	TB1-6	WHITE-BLACK	22 AWG
A100-2	TB2-1	BLACK	18 AWG
A100-3	J2-13	WHITE-RED	24 AWG
A100-6		CABLE SHIELD	SHIELD
A100-7	J5-1	BROWN-BLACK	18 AWG
A100-8	J2-9	WHITE-BLACK-BLUE	24 AWG
A100-9		CABLE SHIELD	SHIELD
A100-10	J3-7	WHITE-GREEN	22 AWG
A100-11	J2-10	WHITE-BLACK-RED	24 AWG
A100-12	TB1-6	CABLE SHIELD	SHIELD
A100-13		CABLE SHIELD	SHIELD
A100-14	J4-1	CABLE CONDUCTOR	24 AWG
A100-15	J4-2	WHITE-BROWN-ORANGE	24 AWG
A100-16	J5-2	WHITE-YELLOW-GREEN	22 AWG
A100-17	J5-2	BROWN-GREEN	18 AWG
A100-18	TB1-4	CABLE CONDUCTOR	24 AWG
A100-19	J6-1	CABLE CONDUCTOR	24 AWG
A100-20	J5-1	WHITE-BROWN	22 AWG
A100-21	R2-1	WHITE-YELLOW-GRAY	24 AWG
A100-22	A600-2	WHITE-RED-VIOLET	24 AWG
A100-23		CABLE SHIELD	SHIELD
A100-24	J3-9	CABLE CONDUCTOR	24 AWG
A100-25	A700 R3-1	CABLE CONDUCTOR	24 AWG
A100-28	A900 R4B-3	WHITE-BLACK-BROWN	22 AWG
A100-29	S3-12	WHITE-ORANGE-GREEN	22 AWG
A100-30	TB2-2	WHITE-BLACK-ORANGE	24 AWG
A100-31	J4-8	WHITE-GREEN-VIOLET	24 AWG
A100-32	C1-2	WHITE-BLACK	18 AWG
A100-33	J4-9	WHITE-GREEN-GRAY	24 AWG
A100-34	J4-15	WHITE-RED-YELLOW	24 AWG
A100-35	A600-4	WHITE-RED-ORANGE	24 AWG
A100-36	A600-3	WHITE-RED-YELLOW	24 AWG
A100-37	A900 R4A-3	WHITE-GRAY	18 AWG
A100-38	J8-1	WHITE-GREEN-GRAY	18 AWG
A100-39	S3-14	WHITE-RED-ORANGE	22 AWG
A600-1	CHASSIS	WHITE-RED-BLUE	24 AWG
A600-2	A100-22	WHITE-RED-VIOLET	24 AWG
A600-3	A100-36	WHITE-RED-YELLOW	24 AWG
A600-4	A100-35	WHITE-RED-ORANGE	24 AWG
A600-5	CHASSIS	WHITE-RED-BLUE	24 AWG
A600-6	J4-14	CABLE CONDUCTOR	24 AWG
A600-7	J4-13	CABLE CONDUCTOR	24 AWG
C1-1	TB2-1	BLACK	18 AWG
C1-2	A100-32	WHITE-BLACK	18 AWG
J1-1	S2-1	WHITE-GRAY	18 AWG
J1-2	CHASSIS	GREEN-YELLOW	18 AWG
J1-3	XF1-1	WHITE-BLACK-GRAY	18 AWG
J2-1	T1-6	WHITE-VIOLET	22 AWG
J2-2	T1-5	VIOLET	22 AWG

Table 4-4. ZM-71A/U Wire List (Continued)

FROM	TO	COLOR CODE	WIRE SIZE
J2-3	T1-7	VIOLET	22 AWG
J2-4	J3-2	WHITE-ORANGE	22 AWG
J2-4	J4-4	WHITE-ORANGE	22 AWG
J2-4	S3-3	WHITE-ORANGE	22 AWG
J2-5	CHASSIS	BLACK	22 AWG
J2-5	J2-15	WHITE-BROWN-GREEN	22 AWG
J2-6	J3-1	WHITE-VIOLET	22 AWG
J2-6	J4-3	WHITE-VIOLET	22 AWG
J2-6	S3-6	WHITE-VIOLET	22 AWG
J2-7	T1-8	BROWN	22 AWG
J2-8	T1-9	BROWN	22 AWG
J2-9	A100-8	WHITE-BLACK-BLUE	24 AWG
J2-9	T1-11	BLUE	22 AWG
J2-10	A100-11	WHITE-BLACK-RED	24 AWG
J2-11	T1-10	BLUE	22 AWG
J2-12	CHASSIS	WHITE-RED-BLUE	22 AWG
J2-12	T1-12	ORANGE	22 AWG
J2-13	A100-3	WHITE-RED	24 AWG
J2-13	S3-15	WHITE-RED	22 AWG
J2-14	T1-13	ORANGE	22 AWG
J2-15	J2-5	WHITE-BROWN-GREEN	22 AWG
J2-15	J9-1	WHITE-BROWN-GREEN	22 AWG
J2-16	S3-9	CABLE CONDUCTOR	24 AWG
J2-17	S3-2	WHITE-ORANGE-YELLOW	22 AWG
J2-18	S3-5	WHITE-BLUE-VIOLET	22 AWG
J3-1	J2-6	WHITE-VIOLET	22 AWG
J3-2	J2-4	WHITE-ORANGE	22 AWG
J3-3	OPEN		-----
J3-4	OPEN		-----
J3-5	OPEN		-----
J3-6	OPEN		-----
J3-7	A100-10	WHITE-GREEN	22 AWG
J3-8	CHASSIS	BLACK	22 AWG
J3-9	A100-24	CABLE CONDUCTOR	24 AWG
J3-10	OPEN		-----
J3-11	OPEN		-----
J3-12	OPEN		-----
J3-13	OPEN		-----
J3-14	OPEN		-----
J3-15	J4-12	CABLE CONDUCTOR	24 AWG
J4-1	A100-14	CABLE CONDUCTOR	24 AWG
J4-2	A100-15	WHITE-BROWN-ORANGE	24 AWG
J4-3	J2-6	WHITE-VIOLET	22 AWG
J4-4	J2-4	WHITE-ORANGE	22 AWG
J4-5	CHASSIS	BLACK	22 AWG
J4-6	S3-17	WHITE-BROWN-VIOLET	22 AWG
J4-7	S3-18	WHITE-BROWN-GRAY	22 AWG
J4-7	TB3-1	WHITE-BROWN-YELLOW	22 AWG
J4-8	A100-31	WHITE-GREEN-VIOLET	24 AWG

Table 4-4. ZM-71A/U Wire List (Continued)

FROM	TO	COLOR CODE	WIRE SIZE
J4-9	A100-33	WHITE-GREEN-GRAY	24 AWG
J4-10	S3-11	WHITE-GREEN-BLUE	22 AWG
J4-11	CHASSIS	BLACK	22 AWG
J4-11	-	CABLE SHIELD	22 AWG
J4-12	J3-15	CABLE CONDUCTOR	24 AWG
J4-13	A600-7	CABLE CONDUCTOR	24 AWG
J4-14	A600-6	CABLE CONDUCTOR	24 AWG
J4-15	A100-34	WHITE-RED-YELLOW	24 AWG
J5-1	A100-7	BROWN-BLACK	18 AWG
J5-1	A100-20	WHITE-BROWN	22 AWG
J5-2	A100-17	BROWN-GREEN	18 AWG
J5-2	A100-16	WHITE-YELLOW-GREEN	22 AWG
J6-1	A100-19	CABLE CONDUCTOR	24 AWG
J6-2	TB1-3	CABLE CONDUCTOR	24 AWG
J7-1	R5A-1	WHITE-BLACK-GREEN	22 AWG
J7-2	-	CABLE SHIELD	22 AWG
J7-2	TB3-2	BLACK	22 AWG
J8-1	A100-38	WHITE-GREEN-GRAY	18 AWG
J8-2	R5B-3	WHITE-GREEN-GRAY	18 AWG
J9-1	J2-15	WHITE-BROWN-GREEN	24 AWG
J9-1	T2-5	RED	22 AWG
J9-2	S3-7	WHITE-BROWN-RED	22 AWG
J10-1	TB3-2	BLACK	22 AWG
J10-2	OPEN		-----
M1-1	R2-2	WHITE-YELLOW	24 AWG
M1-2	R2-3	WHITE-BLUE	24 AWG
R2-1	A100-21	WHITE-YELLOW	24 AWG
R2-2	M1-1	YELLOW-WHITE	22 AWG
R2-3	M1-2	WHITE-BLUE	22 AWG
R2-3	TB2-1	BLACK	24 AWG
R3-1	A100-25	CABLE CONDUCTOR	24 AWG
K3-2	TB2-1	BLACK	18 AWG
R4A-1	R5B-4	WHITE-YELLOW-GRAY	18 AWG
R4A-2	R4A-3	JUMPER	22 AWG
R4A-3	A100-37	WHITE-GRAY	18 AWG
R4A-3	R4A-2	JUMPER	22 AWG
R4B-1	R5A-2	WHITE-BLACK-YELLOW	22 AWG
R4B-2	R4B-3	JUMPER	22 AWG
R4B-3	A100-28	WHITE-BLACK-BROWN	22 AWG
R4B-3	R4B-2	JUMPER	22 AWG
R5A-1	J7-1	WHITE-BLACK-GREEN	22 AWG
R5A-2	R4B-1	WHITE-BLACK-YELLOW	22 AWG
R5B-3	J8-2	WHITE-GREEN-GRAY	18 AWG
R5B-4	R4A-1	WHITE-YELLOW-GRAY	18 AWG
S1-1	OPEN		-----
S1-2	S1-5	JUMPER	22 AWG
S1-3	S1-6	JUMPER	22 AWG
S1-5	S1-2	JUMPER	22 AWG
S1-5	XF1-2	CABLE/WHITE-BROWN-GRAY	22 AWG

Table 4-4. ZM-71A/U Wire List (Continued)

FROM	TO	COLOR CODE	WIRE SIZE
S1-6	S1-3	JUMPER	22 AWG
S1-6	S2-4	GRAY	22 AWG
S2-1	T1-14	BROWN-RED	22 AWG
S2-1	J1-1	WHITE-GRAY	22 AWG
S2-2	T1-15	BLACK-YELLOW	22 AWG
S2-3	S2-6	JUMPER	22 AWG
S2-4	T1-2	BLACK	22 AWG
S2-4	S1-6	CABLE/GRAY	22 AWG
S2-5	T1-4	BLACK-GREEN	22 AWG
S2-6	S2-3	JUMPER	22 AWG
S3-1	OPEN		-----
S3-2	J2-17	WHITE-ORANGE-YELLOW	22 AWG
S3-3	J2-4	WHITE-ORANGE	22 AWG
S3-4	OPEN		-----
S3-5	J2-18	WHITE-BLUE-VIOLET	22 AWG
S3-6	J2-6	WHITE-VIOLET	22 AWG
S3-7	J9-2	WHITE-BROWN-RED	22 AWG
S3-8	T2-9	BROWN	24 AWG
S3-9	J2-16	CABLE CONDUCTOR	24 AWG
S3-10	OPEN		-----
S3-11	J4-10	WHITE-GREEN-BLUE	22 AWG
S3-12	A100-29	WHITE-ORANGE-GREEN	22 AWG
S3-13	OPEN		-----
S3-14	A100-39	WHITE-RED-ORANGE	22 AWG
S3-15	J2-13	WHITE-RED	22 AWG
S3-16	OPEN		-----
S3-17	J4-6	WHITE-BROWN-VIOLET	22 AWG
S3-18	J4-7	WHITE-BROWN-GRAY	22 AWG
T1-1	OPEN		-----
T1-2	S2-4	BLACK	22 AWG
T1-3	OPEN		-----
T1-4	S2-5	BLACK-GREEN	22 AWG
T1-5	J2-2	VIOLET	22 AWG
T1-6	J2-1	WHITE-VIOLET	22 AWG
T1-7	J2-3	VIOLET	22 AWG
T1-8	J2-7	BROWN	22 AWG
T1-9	J2-8	BROWN	22 AWG
T1-10	J2-11	BLUE	22 AWG
T1-11	J2-9	BLUE	22 AWG
T1-12	J2-12	ORANGE	22 AWG
T1-13	J2-14	ORANGE	22 AWG
T1-14	S2-1	BLUE-RED	22 AWG
T1-15	S2-2	BLACK-YELLOW	22 AWG
T2-1	TB1-3	YELLOW	22 AWG
T2-2	TB1-6	GRAY	24 AWG
T2-3	TB1-4	YELLOW	22 AWG
T2-4	TB1-6	GRAY	24 AWG
T2-5	J9-1	RED	24 AWG
T2-6	TB1-5	GREEN	24 AWG

Table 4-4. ZM-71A/U Wire List (Continued)

FROM	TO	COLOR CODE	WIRE SIZE
T2-7	CHASSIS	BLACK	24 AWG
T2-9	S3-8	BROWN	24 AWG
TB1-3	T2-1	YELLOW	22 AWG
TB1-3	J6-2	CABLE CONDUCTOR	24 AWG
TB1-4	T2-4	YELLOW	22 AWG
TB1-4	A100-18	CABLE CONDUCTOR	24 AWG
TB1-5	T2-6	GREEN	24 AWG
TB1-6	T2-2	GRAY	24 AWG
TB1-6	T2-4	GRAY	24 AWG
TB1-6	A100-12	CABLE SHIELD	SHIELD
TB1-6	A1000-1	WHITE-BLACK	22 AWG
TB2-1	C1-1	BLACK	18 AWG
TB2-1	A100-2	BLACK	18 AWG
TB2-1	R2-3	BLACK	28 AWG
TB2-1	R3-2	BLACK	24 AWG
TB2-2	A100-30	WHITE-BLACK-ORANGE	22 AWG
TB3-1	J4-7	WHITE-BROWN-YELLOW	22 AWG
TB3-2	J10-1	BLACK	22 AWG
TB3-2	J7-2	BLACK	22 AWG
XF1-1	J1-3	WHITE-BLACK-GRAY	18 AWG
XF1-2	S1-5	WHITE-BROWN-GRAY	22 AWG

4-25. RANGE AND FUNCTION SWITCH ASSEMBLY (A100).

- a. Removal. Remove the range and function switch assembly (A100) as follows:
 - 1). Unplug the power cable from the impedance bridge.
 - 2). Remove the top, left and right side covers, and bottom cover (RPSTL figure 1, items 14, 51, and 61).
 - 3). Remove the mounting bracket (RPSTL figure 1, item 53).
 - 4). Turn the range knob pointer straight up, the function knob pointer to R and all other knobs fully counterclockwise.
 - 5). Remove all knobs (RPSTL figure 1, items 7, 8, 9, 12, and 13).
 - 6). Remove the two screws that hold on the front panel (RPSTL figure 1, item 63).
 - 7). Remove the side frames from the chassis (RPSTL figure 1, item 46).
 - 8). Remove the observation window and the front panel (RPSTL figure 1, item 4).
 - 9). Remove the null meter (RPSTL figure 1, item 5).
 - 10). Remove the A600 assembly (RPSTL figure 1, item 68).
 - 11). Remove the DQ dial retainer (RPSTL figure 1, item 85).
 - 12). Remove the two screws that hold the DQ dial assembly (RPSTL figure 1, item 88).
 - 13). Remove variable resistor R4 P/O A900 (RPSTL figure 1, item 88).
 - 14). Tag the wires that go to the binding posts J5A, and J5B (RPSTL figure 2, item 9).
 - 15). Remove binding posts J5A, and J5B (RPSTL figure 2, item 9).
 - 16). Remove switch assembly A800 (RPSTL figure 1, item 80).
 - 17). Tag and unsolder all wires connected to the A100 printed wiring board.
 - 18). Remove the A100 assembly (RPSTL figure 1, item 74).

- b. Repair. Repair of the RANGE and FUNCTION switch assembly (A100) is limited to replacement of those repair parts shown in the RPSTL (TM 11-6625-3077-24P). No other repair is authorized.

c. Replacement. Replace the A100 assembly as follows:

- 1). Solder all tagged wires to the printed wiring board.
- 2). Replace switch assembly A800 (two screws).
- 3). Replace binding posts J5A, and J5B and solder the tagged wires to the terminal post.
- 4). Replace variable resistor R4 P/O A900 to the A100 chassis making sure the index slot is in its proper place (one nut, one flat washer and one lockwasher behind panel).
- 5). Replace the DQ dial assembly (two screws).
- 6). Replace the DQ dial retainer (two screws).
- 7). Replace the A600 assembly (two screws).
- 8). Replace the null meter (two screws).
- 9). Replace the front panel.
- 10). Replace the left side frame (seven screws).
- 11). Replace the front panel screw on the left side.
- 12). Replace the observation window.
- 13). Replace the right side frame (twelve screws).
- 14). Replace the front panel screw on the right side.
- 15). Insure that the FUNCTION switch is on R (no symbol in the function range window), the RANGE switch is on the lowest Kohms position, and all other controls are fully counterclockwise.
- 16). Replace all knobs. The function knob pointer on R, the range knob pointer straight up, the sensitivity knob pointer at seven o'clock, and the DQ VERNIER knob pointer on CAL.

d. Operational Check. Check the operation of the RANGE and FUNCTION switch assembly (A100) as follows:

- 1). Connect the test equipment as shown.

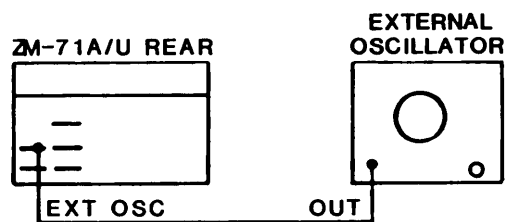

- 2). Set the impedance bridge controls as follows:
 - FUNCTION switch Cp HIGH D
 - RANGE switch to nF with the left
decimal point on (XX.XX)
 - CRL counter to 1000
 - SENSITIVITY Fully clockwise
 - DQ VERNIER to CAL
 - DQ control to midrange
 - INT/EXT switch to EXT
 - Power switch to ON

- 3). Set the external oscillator controls as follows:
 - Frequency to 1,000 Hz
 - Voltage output 2 V maximum
 - Power switch to ON

- 4). Connect the 0.01 UF silvered mica capacitor with 160,000 ohms PORM 5%, 0.25W fixed resistor in parallel to the impedance bridge UNKNOWN terminals.

- 5). Adjust the CRL control to null the meter.

- 6). Record the reading on the numerical counter.

- 7). Remove the 160,000 ohm resistor and connect the 330 ohms PORM 5%, 0.25W fixed resistor in parallel to the 0.01uF capacitor and the impedance bridge UNKNOWN terminals.

- 8). Set the external oscillator controls as follows:
 - Frequency 20,000 Hz

- 9). Adjust the CRL control to null the meter.

- 10). Adjust C103 slightly for a minimum reading on the CRL numerical counter.

- 11). Record the reading on the numerical counter.

- 12). Repeat steps 3 thru 11 until the difference between the two readings is minimum.

- 13). Set the impedance bridge controls as follows:
 - FUNCTION switch Cp HIGH D
 - RANGE switch to pF with the right
decimal point on (XXXX.)
 - CRL counter to 1000
 - SENSITIVITY Fully clockwise
 - DQ VERNIER to CAL
 - DQ control to midrange
 - INT/EXT switch to EXT
 - Power switch to ON

- 14). Set the external oscillator controls as follows:
 - Frequency to 1,000 Hz
 - Voltage output 2 V maximum
 - power switch to ON
- 15). Connect the 1000 pF silvered mica capacitor with 1,600,000 ohms PORM 5%, 0.25W fixed resistor in parallel to the impedance bridge UNKNOWN terminals.
- 16). Adjust the CRL control to null the meter.
- 17). Record the reading on the numerical counter.
- 18). Remove the 1,600,000 ohm resistor and connect the 3300 ohms PORM 5%, 0.25w fixed resistor in parallel to the 1000 pF capacitor and the impedance bridge UNKNOWN terminals.
- 19). Set the external oscillator controls as follows:
 - Frequency 20,000 Hz
- 20). Adjust the CRL control to null the meter.
- 21). Adjust C104 slightly for a minimum reading on the CRL numerical counter .
- 22). Record the reading on the numerical counter.
- 23). Repeat steps 14 thru 22 until the difference between the two readings is minimum.
- 24). Set the impedance bridge controls as follows:
 - FUNCTION switch Ls LOW Q
 - RANGE switch uH with right
decimal point on (XXXX.)
 - CRL counter 1000
 - DQ VERNIER CAL
 - DQ control midrange
 - SENSITIVITY fully clockwise
 - EXT/INT switch EXT
 - Power switch ON
- 25). Set the external oscillator controls as follows:
 - Frequency 1,000 Hz
 - Voltage 2 V maximum
 - Power switch ON
- 26). Connect a 1 mH standard inductor to the impedance bridge UNKNOWN terminals.
- 27). Adjust the CRL control for a null on the meter.
- 28). Record the reading on the numerical counter.

- 29). Install a 330 ohm PORM 5%, 0.25w fixed resistor in series with the 1mH standard inductor and the high (unmarked) UNKNOWN terminal.
- 30). Set the external oscillator controls as follows:
Frequency 20,000 Hz
- 31). Adjust the CRL control for a null on the meter.
- 32). Compare the results of readings in step 28 and step 31. Inductance differences should be within PORM 0005uH. If not within 0005uH, measure the resistance between UNKNOWN low terminal and pin 40 on the A100 printed wiring board as follows.
- 33). Remove power from the impedance bridge.
- 34). Remove the A200, A300 and A400 circuit card assemblies.
- 35). Set the impedance bridge FUNCTION switch to Lp LOW Q.
- 36). Remove the shorting strap on the BIAS BATTERY terminal.
- 37). With an ohmmeter measure the resistance between the UNKNOWN low terminal and pin 40 on the A100 printed wiring board (para 4-22).
- 38). If the ohmmeter reading is 1 ohm PORM 0.5%, select C101 for the inductance difference as specified in step 32. If the ohmmeter reading is not 1 ohm PORM 0.5%, check switch contacts S101 and S102.
- 39). If these readings are not obtained, refer to table 4-3 for troubleshooting procedures.
- 40). Remove power and replace the mounting bracket (four screws).
- 41). Replace the top cover (two screws), bottom cover (two screws), side covers (four screws each), and shorting straps.

4-26, POWER SUPPLY AND 1KHz OSCILLATOR CIRCUIT CARD ASSEMBLY (A200).

- a. Remval. Remove the power supply and 1KHZ circuit card assembly (A200) as follows:
 - 1). Unplug the power cable from the impedance bridge.
 - 2). Remove the top and bottom cover (RPSTL figure 1, items 14, and 61).
 - 3). Remove the mounting bracket (RPSTL figure 1, item 53).
 - 4). Carefully pull up on the circuit card assembly until it releases from the connector.
- b. Repair. Repair of the power supply and 1KHz oscillator circuit card assembly (A200) is limited to replacement of those repair parts shown in the RPSTL (TM 11-6625-3077-24P). No other repair is authorized.

- c. Replacement. Replace the circuit card assembly (A200) as follows:
 - 1). Insert the circuit card assembly, with the components facing forward, and align the bottom to the connector (J2) on the chassis.
 - 2). Carefully push on both ends of the circuit card with equal pressure until it slides into the connector.
- d. Operational Check. Check the operation of the power supply and 1KHz oscillator circuit card assembly (A200) as follows:
 - 1). Connect the test equipment as shown.

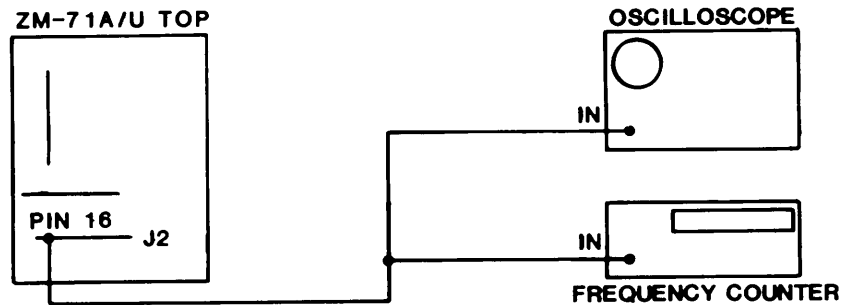

- 2). Set the impedance bridge controls as follows:
 - FUNCTION switch R
 - RANGE switch to Kohms with the left decimal point on (XX.XX)
 - CRL counter to 1000
 - SENSITIVITY Fully clockwise
 - DQ VERNIER to CAL
 - DQ control to midrange
 - INT/EXT switch to INT
 - Power switch to ON
- 3). Set the oscilloscope controls as follows:
 - Time 200uS/cm
 - Voltage 1V/cm
 - Power switch to ON
- 4). Set the frequency counter controls as follows:
 - Frequency 1000Hz
 - Power switch ON
- 5). Adjust R213 for a level between 4.5 and 6.7 volts peak-to-peak with positive peaks clipped not more than 100 microseconds.
- 6). Adjust R210 for a frequency of between 995 to 1005Hz.

- 7). Repeat steps 5 and 6 until both measurements are within these values.
- 8). Set the DC voltmeter to measure applicable voltages.
- 9). Connect the DC voltmeter to J2 pin D (TP1). Voltmeter should measure between +12.0 and +13.5Vdc.
- 10). Connect the DC voltmeter to J2 pin F (TP2). Voltmeter should measure between -11.0 and -12.5Vdc.
- 11). Connect the DC voltmeter to J2 pin P (TP3). Voltmeter should measure between +95.0 and +115Vdc.
- 12). Set the oscilloscope controls as follows:

Voltage 1V/cm
Sweep speed 200uS/cm
Power switch ON
- 13). Connect the oscilloscope to J2 pin T (TP4). Voltage level should be between 4.5 and 6.7 volts peak-to-peak (paragraph 4-22).
- 14). If these readings are not obtained, refer to table 4-3 troubleshooting procedures.
- 15). Remove power and replace mounting bracket and the top and bottom covers.

4-27. REFERENCE VOLTAGE CIRCUIT CARD ASSEMBLY (A300).

- a. Removal. Remove the reference voltage circuit card assembly (A300) as follows:
 - 1). Unplug the power cable from the impedance bridge.
 - 2). Remove the top and bottom cover (RPSTL figure 1, items 14, and 61).
 - 3). Remove the mounting bracket (RPSTL figure 1, item 53).
 - 4). Carefully pull up on the circuit card assembly until it releases from the connector.
- b. Repair. Repair of the reference voltage circuit card assembly (A300) is limited to replacement of those repair parts shown in the RPSTL (TM 11-6625-3077-24P). No other repair is authorized.
- c. Replacement. Replace the circuit card assembly (A300) as follows:
 - 1). Insert the circuit card assembly, with the components facing forward, and align the bottom to the connector (J3) on the chassis.
 - 2). Carefully push on both ends of the circuit card with equal pressure until it slides into the connector.

d. Operational Check. Check the operation of the reference voltage circuit card assembly (A300) as follows:

1). Connect the test equipment as shown.

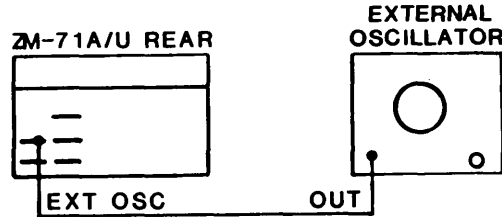

2). Set the impedance bridge controls as follows:

- FUNCTION switch Cp HIGH D
- RANGE switch to nF with the middle
decimal point on (XXX.X)
- CRL counter to 1000
- SENSITIVITY Fully clockwise
- DQ VERNIER to CAL
- DQ control to midrange
- INT/EXT switch to EXT
- Power switch to ON

3). Set the external oscillator controls as follows:

- Frequency 1000Hz
- Voltage 2 V maximum
- Power switch to ON

4). Connect the 0.1 uF standard capacitor with 16,000 ohm PORM 5%, 0.25W fixed resistor in parallel to the impedance bridge UNKNOWN terminals.

5). Adjust the CRL control to null the meter.

6). Record the reading on the numerical counter.

7). Remove the 160,000 ohm resistor and connect the 33 ohms PORM 5%, 0.25W fixed resistor in parallel to the 0.1UF standard capacitor and the impedance bridge UNKNOWN terminals.

8). Set the external oscillator controls as follows:

- Frequency 20,000Hz

9). Adjust the CRL control to null the meter.

10). The difference between the readings in step 6 and 9 should be within PORM 0.2nF. If not, change the value of C305.

- 11). Repeat steps 3 thru 10 until the difference between the two readings is within 0.2nF.
- 12). Remove power from the impedance bridge.
- 13). Disconnect the white-green-blue wire. from J4, pin 10, and connect it to terminal 3 of DQ resistor R5A P/O A900.
- 14). Set the impedance bridge controls as follows:
 - FUNCTION switch Cp AUTO
 - RANGE switch to nF with the middle decimal point on (XXX.X)
 - CRL counter to 1000
 - SENSITIVITY Fully clockwise
 - DQ VERNIER to CAL
 - DQ control to midrange
 - INT/EXT switch to EXT
 - Power switch OFF
- 15). Connect a 0.1 uF standard capacitor with 27,000 ohm PORM 5%, 0.25W fixed resistor in parallel to the impedance bridge UNKNOWN terminals.
- 16). Remove circuit card assembly A400 and install a 15 pin extender board in J4. With the components facing inward, insert A400 into the extender board.
- 17). Set the oscilloscope controls as follows:
 - Voltage 1V/cm
 - Sweep speed N/A
 - Power switch ON
- 18). Connect the oscilloscope to A400 TP19. Apply power to the impedance bridge and adjust the CRL control and DQ controls for a minimum amplitude.
- 19). The CRL counter should read between 095.0 and 105.0nF, and the D reading on the DQ dial should read between 0.053 and 0.065 on high D.
- 20). Remove power from the impedance bridge.
- 21). Remove the 15 pin extender board and replace A400.
- 22). Remove the A300 circuit card assembly and install the 15 pin extender board in J3.
- 23). With the components facing forward, place A300 into the extender board.
- 24). Apply power to the impedance bridge.
- 25). Set the oscilloscope controls as follows:
 - Voltage As specified (paragraph 4-22).
 - Sweep time As specified (paragraph 4-22).
 - Power switch ON.

- 26). Observe the waveforms at A300 TP5 thru TP16. Compare the waveforms to the ones illustrated in paragraph 4-22.
- 27). If these readings are not obtained, refer to table 4-3 for troubleshooting procedures.
- 28). Remove power and replace the white-green-blue wire to J4 pin 10.
- 29). Replace the mounting bracket (four screws).
- 30). Replace the top cover (two screws), bottom cover (two screws), and side covers (four screws each).

4-28. DETECTOR CIRCUIT CARD ASSEMBLY (A400).

- a. Removal. Remove the detector circuit card assembly (A400) as follows:
 - 1). Unplug the power cable from the impedance bridge.
 - 2). Remove the top and bottom cover (RPSTL figure 1, items 14. and 61).
 - 3). Remove the mounting bracket (RPSTL figure 1, item 53).
 - 4). Carefully pull up on the circuit card assembly until it releases from the connector.
- b. Repair. Repair of the detector circuit card assembly (A400) is limited to replacement of those repair parts shown in the RPSTL (TM 11-6625-3077-24P). No other repair is authorized.
- c. Replacement. Replace the circuit card assembly (A400) as follows:
 - 1). Insert the circuit card assembly, with the components facing inward, and align the bottom to the connector (J4) on the chassis.
 - 2). Carefully push on both ends of the circuit card with equal pressure until it slides into the connector.
- d. Operational Check. Check the operation of the detector circuit card assembly (A400) as follows:
 - 1). Connect the test equipment as shown.

- 2). Disconnect the shielded cable from J4, pin 1.
- 3). Set the impedance bridge controls as follows:
 - FUNCTION switch R
 - RANGE switch to kohms with the left
decimal point on (XX.XX)
 - CRL counter to 1000
 - SENSITIVITY Fully clockwise
 - DQ VERNIER to CAL
 - DQ control to midrange
 - INT/EXT switch to EXT
 - Power switch to ON
- 4). Set the external oscillator controls as follows:
 - Frequency 1000Hz
 - Voltage 1 V peak-to-peak
 - Power switch to ON
- 5). Set the oscilloscope controls as follows:
 - Channel A0.2V/cm, polarity +up
 - Channel B0.2V/cm, polarity -up
 - Trigger EXT
 - Function Chopped
 - Power switch ON
- 6). Set the electronic counter controls as follows:
 - Frequency 1000Hz
 - Power switch ON.
- 7). Alternately adjust R415 and R417 so that the oscillator output voltage and J4 pin 7 voltage are in phase and J4 pin 7 voltage level is between 0.9 and 1.1 volt peak to peak.
- 8). Remove power from the impedance bridge. Connect the shielded cable to J4, pin 1.
- 9). Disconnect the white-green-blue wire from J4, pin 10, and connect it to terminal 3 of DQ resistor R5A.
- 10). Set the impedance bridge controls as follows:
 - FUNCTION switch Cp AUTO
 - RANGE switch to nF with the middle
decimal point on (XXX.X)
 - CRL counter to 1000
 - SENSITIVITY Fully clockwise
 - DQ VERNIER to CAL
 - DQ control to midrange
 - INT/EXT switch to EXT
 - Power switchOFF

- 11). Connect a 0.1 uF standard capacitor with 27,000 ohm PORM 5%, 0.25W fixed resistor in parallel to the impedance bridge UNKNOWN terminals.
- 12). Remove circuit card assembly A400 and install a 15 pin extender board in J4. With the components facing inward, insert A400 into the extender board.
- 13). Set the oscilloscope controls as follows:
 Voltage 1V/cm
 Sweep speed N/A
 Power switch ON
- 14). Connect the oscilloscope to A400 TP19. Apply power to the impedance bridge and adjust the CRL control and DQ controls for a minimum amplitude.
- 15). The CRL counter should read between 095.0 and 105.0nF, and the D reading on the DQ dial should read between 0.053 and 0.065 on high D.
- 16). Set the oscilloscope controls as follows:
 Voltage As specified (paragraph 4-22).
 Sweep time As specified (paragraph 4-22).
 Power switch ON.
- 17). Observe the waveforms at A400 TP17 and TP18. Compare the waveforms to the ones illustrated in paragraph 4-22.
- 18). Using a DC voltmeter with an input impedance greater than 10,000,000 ohms, measure the voltages at A400 TP19 and TP20, TP19 and TP21. Compare the voltages to the ones listed in paragraph 4-22).
- 19). Using the oscilloscope measure the waveforms at A400 TP22 and TP23. TP22A and TP23A show the waveform if the CRL control is adjusted 0.2% high from the balance point established in step 14.
- 20). A400 TP22B and TP23B show the waveform if the CRL control is adjusted 0.2% low from the balance point established in step 14.
- 21). Remove power from the impedance bridge.
- 22). Connect the test equipment as shown below:

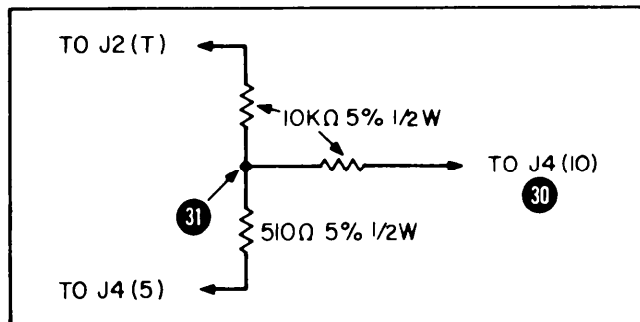

- 23). Connect the resistance network as shown above.

- 24). Set the impedance bridge controls as follows:
 - FUNCTION switch Cp AUTO
 - RANGE switch to nF with middle
decimal point on (XXX.X)
 - CRL counter to 1000
 - SENSITIVITY Fully clockwise
 - DQ VERNIER to CAL
 - DQ control to midrange
 - INT/EXT switch to EXT
 - Power switch OFF
- 25). Connect a 0.1 uF standard capacitor with 27,000 ohm PORM 5%, 0.25W fixed resistor in parallel to the impedance bridge UNKNOWN terminals.
- 26). Remove circuit card assembly A400 and install a 15 pin extender board in J4. With the components facing inward, insert A400 into the extender board.
- 27). Set the oscilloscope controls as follows:
 - Voltage 0.005V/cm (0.05V/cm with 10:1 probe)
 - Sweep speed N/A
 - Power switch ON
- 28). Connect the oscilloscope to A400 TP30. Apply power to the impedance bridge and adjust the CRL control and DQ controls for a bridge balance (null). (For example assume the CRL counter is reading 102.0nF and the D reading is 0.062).
- 29). Change the CRL control to +0.2% above bridge balance (to 102.2nF for example above).
- 30). Verify that the 1KHz signal is on the oscilloscope, and is no more than 30mV peak-to-peak.
- 31). Quickly shift the CRL control by -0.2% below the balance reading (to 101.8nF for example above). At first there is no 1KHz signal but after 10 seconds it will appear.
- 32). Quickly shift the CRL control +0.027% of the balance reading (to 102.2nF for example above). After a few seconds the 1KHz signal will disappear.
- 33). Select a value of R442 so that the time constant when the CRL control is decreased and increased by 0.02% are about the same.
- 34). With a DC voltmeter, measure the voltages at A400 TP32 and TP33 in both the 0.02% above and below balance position. Compare these voltages to the ones listed in paragraph 4-22.
- 35). If these readings are not obtained, refer to table 4-3 for troubleshooting procedures.
- 36). Remove power and replace the white-green-blue wire to J4 pin 10.

- 37). Replace the mounting bracket (four screws).
- 38). Replace the top cover (two screws), bottom cover (two screws), and side covers (four screws each).

4-29. LAMP CIRCUIT CARD ASSEMBLY (A600).

- a. Removal. Remove the range and function switch assembly (A600) as follows:
 - 1). Unplug the power cable from the impedance bridge.
 - 2). Remove the top, left and right side covers, and bottom cover (RPSTL figure 1, items 14, 51, and 61).
 - 3). Remove the mounting bracket (RPSTL figure 1, item 53).
 - 4). Turn the range knob pointer straight up, the function knob pointer to R and all other knobs fully counterclockwise.
 - 5). Remove all knobs (RPSTL figure 1, items 7, 8, 9, 12, and 13).
 - 6). Remove the two screws that hold on the front panel (RPSTL figure 1, item 63).
 - 7). Remove the side frames from the chassis (RPSTL figure 1, item 46).
 - 8). Remove the observation window and the front panel (RPSTL figure 1, items 4 and 11).
 - 9). Remove the two screws holding on the A600 assembly (RPSTL figure 1, item 70).
 - 10). Tag all of the wires connected to the A600 assembly, and unsolder them.
- b. Repair. Repair of the lamp circuit card assembly (A600) is limited to replacement of those repair parts shown in the RPSTL (TM 11-6625-3077-24P). No other repair is authorized.
- c. Replacement. Replace the A600 assembly as follows:
 - 1). Solder all tagged wires to the printed wiring board.
 - 2). Replace the A600 assembly (two screws).
 - 3). Replace the front panel.
 - 4). Replace the left side frame (seven screws).
 - 5). Replace the front panel screw on the left side.
 - 6). Replace the observation window.
 - 7). Replace the right side frame (twelve screws).

- 8). Replace the front panel screw on the right side.
 - 9). Insure that the FUNCTION switch is on r (no symbol in the function range window), the RANGE switch is on the lowest Kohms position, and all other controls are fully counterclockwise.
 - 10). Replace all knobs. The function knob pointer on R, the range knob pointer straight up, the sensitivity knob pointer at seven o'clock, and the DQ vernier knob pointer on CAL.
 - 11). Replace the mounting bracket (four screws).
 - 12). Replace the top (two screws), bottom (two screws), and side covers (four screws each).
- d. Operational Check. Check the operation of the lamp circuit card assembly (A600) as follows:
- 1). Apply power to the impedance bridge.
 - 2). Set the impedance bridge controls as follows:

FUNCTION switch Ls AUTO
RANGE switch to H
CRL counter to 0000
SENSITIVITY Fully clockwise
 - 3). Observe that one of the direction indicators is on. Vary the CRL control from 0000 to 0010 and observe that the direction indicator lamps both light.
 - 4). Rotate the RANGE switch to each of the H positions (3) and observe that all decimal points light.
 - 5). If the lamps fail to light, refer to table 4-3 for troubleshooting procedures.
 - 6). Remove power from the impedance bridge.

4-30. RESISTOR ASSEMBLY (A700).

- a. Removal. Remove the resistor assembly (A700) as follows:
- 1). Unplug the power cable from the impedance bridge.
 - 2). Remove the top, right side, and bottom cover (RPSTL figure 1, items 14, 51, and 61).
 - 3). Remove the mounting bracket (RPSTL figure 1, item 53).
 - 4). Remove the CRL control knob (RPSTL figure 1, item 7).
 - 5). Remove the right side frame from the chassis (RPSTL figure 1, item 46).

- 6). Tag and unsolder the two wires connected to the A700 assembly.
 - 7). Remove the A700 assembly.
- b. Repair. Repair of the resistor assembly (A700) is limited to replacement of those repair parts shown in the RPSTL (TM 11-6625-3077-24P). No other repair is authorized.
- c. Replacement. Replace the A700 assembly as follows:
- 1). Solder the two tagged wires to the A700 assembly.
 - 2). Position the A700 assembly in place with the CRL control shaft through the front panel.
 - 3). Replace the right side frame (thirteen screws).
 - 4). Replace the CRL counter knob (two setscrews).
- d. Operational Check. Check the operation of the resistor assembly (A700) as follows:
- 1). Remove the power cable from the impedance bridge.
 - 2). Set the impedance bridge controls as follows:
 - CRL counter to 0001
 - power switch OFF
 - 3). Tag and disconnect the shielded cable from the A700 assembly.
 - 4). With a 1% ohmmeter or another impedance bridge, measure the resistance of the A700 assembly (where the cable was removed).
 - 5). Resistance of the A700 assembly should be 5.0 ohms with the counter at 0001. Reconnect the cable to R3.
 - 6). Connect the test equipment as shown.

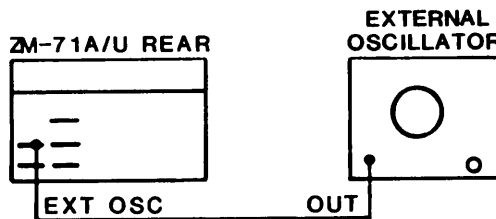

- 7). Set the impedance bridge controls as follows:
 - FUNCTION switch Cp HIGH D
 - RANGE switch to nF with the middle
decimal point on (XXX.X)
 - CRL counter to 1000
 - SENSITIVITY Fully clockwise
 - DQ VERNIER to CAL
 - DQ control to midrange
 - INT/EXT switch to EXT
 - Power switch to ON

- 8). Set the external oscillator controls as follows:
 - Frequency 1000Hz
 - Voltage 1 V peak-to-peak
 - Power switch ON

- 9). Connect the 0.01 uF silvered mica capacitor with 160,000 ohms PORM 5%, 0.25W fixed resistor in parallel to the impedance bridge UNKNOWN terminals.

- 10). Adjust the CRL control to null the meter.

- 11). Record the reading on the numerical counter.

- 12). Remove the 160,000 ohm resistor and connect the 330 ohms PORM 5%, 0.25W fixed resistor in parallel to the 0.01uF capacitor and the impedance bridge UNKNOWN terminals.

- 13). Set the external oscillator controls as follows:
 - Frequency 20,000 Hz

- 14). Adjust the CRL control to null the meter.

- 15). Compare the results of readings in step 11 and 14. Capacitance differences should be within half a digit on the CRL counter.

- 16). If these readings are not obtained, refer to table 4-3 for troubleshooting procedures.

- 17). Replace the mounting bracket (four screws), top (two screws), bottom (two screws), and side covers (four screws each).

4-31. DQ DIAL AND RESISTOR ASSEMBLY (A900).

- a. Removal. Remove the DQ dial and resistor assembly (A900) as follows:
 - 1). Unplug the power cable from the impedance bridge.
 - 2). Remove the top, left and right side covers, and bottom cover (RPSTL figure 1, items 14, 51, and 61).
 - 3). Remove the mounting bracket (RPSTL figure 1, item 53).

- 4). Turn the range knob pointer straight up, the function knob pointer to R and all other knobs fully counterclockwise.
 - 5). Remove all knobs (RPSTL figure 1, items 7, 8, 9, 12, and 13).
 - 6). Remove the two screws that hold on the front panel (RPSTL figure 1, item 63).
 - 7). Remove the side frames from the chassis (RPSTL figure 1, items 46).
 - 8). Remove the observation window and the front panel (RPSTL figure 1, items 4 and 11).
 - 9). Remove the DQ dial retainer (RPSTL figure 1, item 85).
 - 10). Remove the two screws that hold the DQ dial assembly (RPSTL figure 1, item 88).
 - 11). Remove the pulley from the top of R5.
 - 12). Tag and unsolder the wires that go to the DQ dial resistor (R4A and B) and the resistor R5.
 - 13). Remove resistor R5 (RPSTL figure 1, item 88).
 - 14). Remove the DQ dial and resistor R4A and B.
- b. Repair. Repair of the DQ dial and resistor assembly (A900) is limited to replacement of those repair parts shown in the RPSTL (TM 11-6625-3077-24P). No other repair is authorized.
- c. Replacement. Replace the A900 assembly as follows:
- 1). Position the resistor R5 and the DQ dial and resistor (R4) in their proper place.
 - 2). Solder all tagged wires to the resistors R4A and B, and R5.
 - 3). Replace the DQ dial and resistor R4A and B (two screws).
 - 4). Replace the DQ dial retainer (two screws).
 - 5). Replace resistor R5 (three screws).
 - 6). Replace the pulley on R5 but do not tighten setscrews.
 - 7). Replace the front panel.
 - 8). Replace the left side frame (seven screws).
 - 9). Replace the front panel screw on the left side.
 - 10). Replace the observation window.
 - 11). Replace the right side frame (twelve screws).

- 12). Replace the front panel screw on the right side.
 - 13). Insure that the FUNCTION switch is on r (no symbol in the function range window), the RANGE switch is on the lowest Kohms position, and all other controls are fully counterclockwise.
 - 14). Replace all knobs. The function knob pointer on R, the range knob pointer straight up, the sensitivity knob pointer at seven o'clock, and the DQ VERNIER knob pointer on CAL.
- d. Operational Check. Check the operation of the DQ dial and resistor assembly (A900) as follows:
- 1). Set the impedance bridge controls as follows:

DQ control	fully counterclockwise
	so the red index line
	is centered on the last
	0 in 1000 on the top scale
Power switch	OFF
 - 2). Remove the pulley on top of R5.
 - 3). Turn the shaft of R5 fully counterclockwise.
 - 4). Replace the pulley on R5 taking care not to move the DQ dial or the shaft on R5.
 - 5). Tighten setscrews on the pulley.
 - 6). Run performance checks (paragraph 4-16).
 - 7). If the DQ dial fails to operate, refer to table 4-3 for troubleshooting procedures.
 - 8). Replace the mounting bracket (four screws).
 - 9). Replace the top cover (two screws), bottom cover (two screws), and side covers (four screws each).

4-32. VARIABLE CAPACITOR C3.

- a. Removal. Remove the variable capacitor C3 as follows:
 - 1). Unplug the power cable from the impedance bridge.
 - 2). Remove the top, left and right side covers, and bottom cover (RPSTL figure 1, items 14, 51, and 61).
 - 3). Remove the mounting bracket (RPSTL figure 1, item 53).
 - 4). Remove circuit card assemblies A200 and A300 (RPSTL figure 1, items 57 and 58).
 - 5). Unsolder C3 from the terminal strip.

- b. Repair. Not applicable.
- c. Replacement. Replace C3 assembly as follows:
 - 1). Solder wires of C3 on the terminal strip with adjustment screw facing up.
 - 2). Replace circuit card assemblies A200 and A300.
- d. Operational Check. Check the operation of C3 as follows:
 - 1). Connect the test equipment as shown.

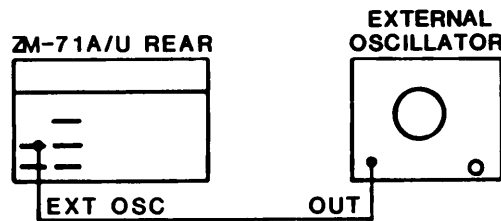

- 2). Set the impedance bridge controls as follows:
 - FUNCTION switch Cp HIGH D
 - RANGE switch to nF with the left
decimal point on (XXX.X)
 - CRL counter to 1000
 - SENSITIVITY Fully clockwise
 - DQ VERNIER to CAL
 - DQ control to midrange
 - INT/EXT switch to EXT
 - Power switch to ON
- 3). Set the external oscillator controls as follows:
 - Frequency 1000Hz
 - Voltage 2 V maximum
 - Power switch to ON
- 4). Connect the 0.01 uF silver mica capacitor with 15,900 ohm PORM 5%, 0.25W fixed resistor in parallel to the impedance bridge UNKNOWN terminals.
- 5). Adjust the CRL control and DQ control to null the meter.
- 6). DQ dial reading should be 1 PORM 0.05.
- 7). Remove power from the impedance bridge.
- 8). Remove the shorting strap on the CpLs DQ resistor terminal.

- 9). With another impedance bridge set-up to measure resistance (about 800 ohms), measure the resistance of the impedance bridge under test between the ungrounded CpLs DQ resistor terminal and the white-black lead at the end of C1.
- 10). Adjust the DQ control of the impedance bridge under test so the second impedance bridge reads 812 ohms.
- 11). Disconnect the second impedance bridge.
- 12). Replace the CpLs terminal shorting strap.
- 13). Apply power to the impedance bridge.
- 14). Without moving the DQ control, balance (null) the impedance bridge by adjusting the CRL control and C3.
- 15). Replace all knobs. The function knob pointer on R, the range knob pointer straight up, the sensitivity knob pointer at seven o'clock, and the DQ VERNIER knob pointer on CAL.
- 16). If these readings can not be obtained, refer to table 4-3 for troubleshooting procedures.
- 17). Remove power and replace the mounting bracket (four screws).
- 18). Replace the top cover (two screws), bottom cover (two screws), and side covers (four screws each).

4-33. MISCELLANEOUS PART REPLACEMENT.

- a. Removal. Remove miscellaneous parts in the impedance bridge as follows:
 - 1). Always make sure equipment is UNPLUGGED before performing any maintenance.

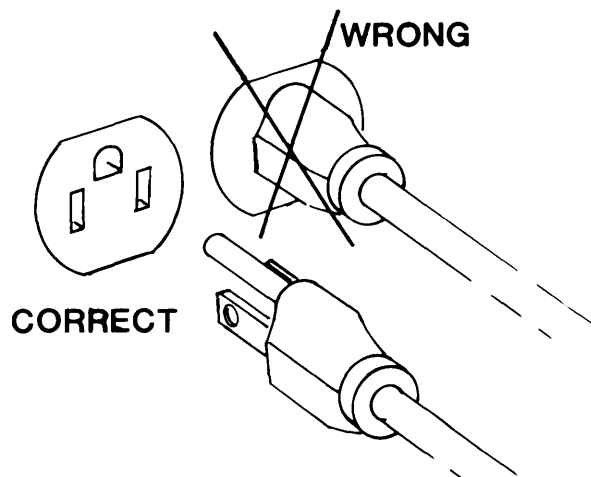

- 2). Always mark wire location before unsoldering connections.

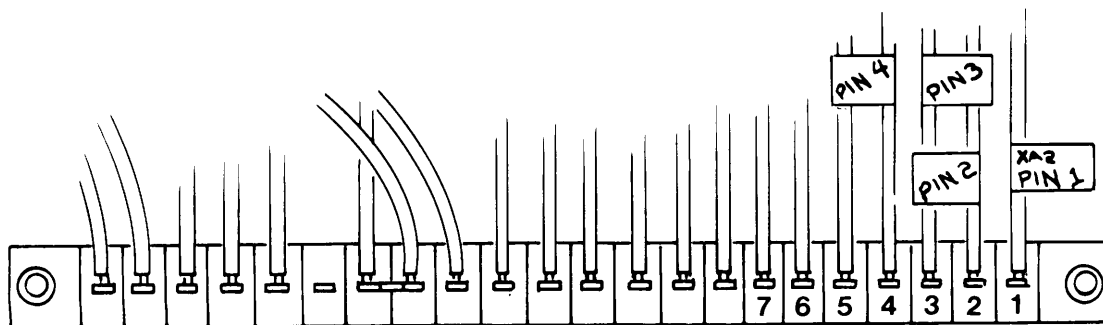

- 3). Note switch positions before removing knobs or switches.
- 4). All parts can be replaced with removal of hardware (screws, nuts, etc) except the following which require rivets to be drilled out.

J1

J2

J3

J4

TB1

TB2

- 5). If removing hardware, replace screws, nuts, etc in there proper place.

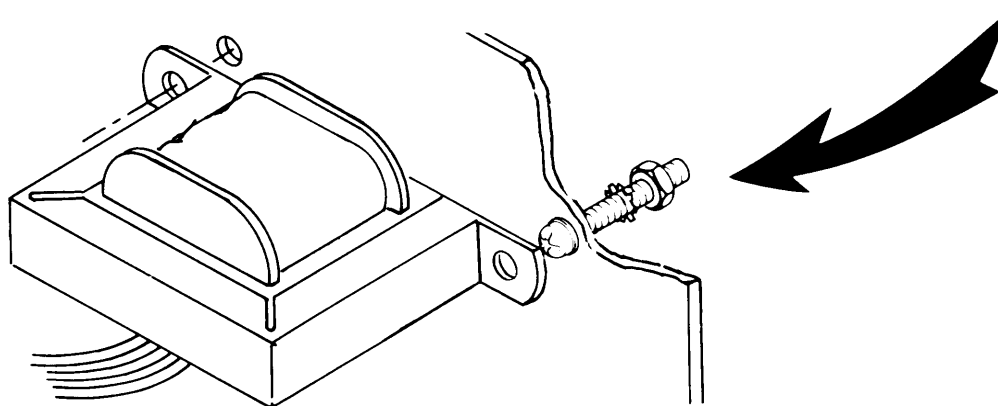

- 6). When replacing, work in reverse order of removal.
- 7). After replacing any part run an operational check (table 4-1, PMCS table).

SECTION VIII. PREPARATION FOR STORAGE OR SHIPMENT

4-34. PACKAGING.

Packaging for limited storage or shipment. Refer to SB 38-100 for material and procedures to be used in packaging the equipment for limited storage or

APPENDIX A

REFERENCES

A-1. SCOPE.

This appendix lists all forms, field manuals, technical manuals and misc. pubs. referenced in this manual.

A-2. FORMS.

Reporting of transportation discrepancies in shipment	AR 55-38
Reporting of item and packaging discrepancies	AR 735-11-2
Discrepancy in shipment report (DISREP)	SF 361
Report of discrepancy (ROD)	SF 364
Quality deficiency report	SF 368
Recommended changes to publications	DA Form 2028-2
Equipment inspection and maintenance worksheet	DA Form 2404
Consolidated index of DA publications and forms	DA Pam 310-1

A-3. FIELD MANUALS.

Packaging for limited storage or shipment, material and procedures	SB 38-100
Field instructions for painting and preserving, electronic equipment	TB 746-10

A-4. TECHNICAL MANUALS.

Repair parts and special tools, ZM-71A/U	TM 11-6625-3077-24P
The Army maintenance management system (TMS)	DA Pam 738-750
Administrative storage procedures	TM 740-90-1
Destruction of Army electronics equipment	TM 750-244-2

APPENDIX B

MAINTENANCE ALLOCATION

SECTION I. INTRODUCTION

B-1. GENERAL.

This appendix provides a summary of the maintenance operations for impedance bridge. It authorizes categories of maintenance for specific maintenance functions on repairable items and components and the tools and equipment required to perform each function. This appendix may be used as an aid in planning maintenance operations.

B-2. MAINTENANCE FUNCTION.

Maintenance functions will be limited to and defined as follows:

a. Inspect. To determine the serviceability of an item by comparing its physical, mechanical, and/or electrical characteristics with established standards through examination.

b. Test. To verify serviceability and to detect incipient failure by measuring mechanical or electrical characteristics of an item and comparing those characteristics with prescribed standards.

c. Service. Operations required periodically to keep an item in proper operating condition, i.e., to clean, preserve, drain, paint, or to replenish fuel/lubricants/hydraulic fluids or compressed air supplies.

d. Adjust. Maintain within prescribed limits by bringing into proper or exact position, or by setting the operating characteristics to the specified parameters.

e. Align. To adjust specified variable elements of an item to about optimum or desired performance.

f. Calibrate. To determine the cause and corrections to be made or adjusted on instruments or test measuring and diagnostic equipment used in precision measurement. This consists of the comparison of two instruments, one of which is a certified standard of known accuracy, to detect and adjust any discrepancy in the accuracy of the instrument being compared.

g. Install. The act of emplacing, seating, or fixing into position an item, part, module (component or assembly in a manner to allow the proper functioning of the equipment/system.)

h. Replace. The act of substituting a serviceable like-type part, subassembly, module (component or assembly) for an unserviceable counterpart .

j. Repair. The application of maintenance services (inspect, test, service, adjust, align, calibrate, replace) or other maintenance actions (welding, grinding, riveting, straightening, facing, remachining, or resurfacing) to restore serviceability to an item by correcting specific damage, fault, malfunction, or failure in a part, subassembly, module/component/assembly, and item or system. This function does not include the trial and error replacement of running spare type items such as fuses, lamps, or electron tubes.

k. Overhaul. That periodic maintenance effort (service/action) necessary to restore an item to a completely serviceable/operational condition as prescribed by maintenance standards (e.g., DWR) in appropriate technical publications. Overhaul is normally the highest degree of maintenance performed by the Army. Overhaul does not normally return an item to like-new condition.

l. Rebuild. Consists of those services/actions necessary for the restoration of unserviceable equipment to a like-new condition in accordance with original manufacturing standards. Rebuild is the highest degree of material maintenance applied to Army equipment. The rebuild operation includes the act of returning to zero those age measurements (hours, miles, etc.) considered in classifying Army equipment/components .

B-3. COLUMN ENTRIES (SECTION II)

a. Column 1, Group Number. Column 1 lists group numbers, the purpose of which is to identify components, assemblies, subassemblies and modules with the next higher assembly.

b. Column 2, component/assembly. Column 2 contains the noun names of components, assemblies, subassemblies, and modules for which maintenance is authorized.

c. Column 3, Maintenance Functions. Column 3 lists the functions to be performed on the item listed in column 2.

d. Column 4, Maintenance Category. Column 4 specifies, by the listing of a "worktime" figure in the appropriate subcolumn(s), the lowest level of maintenance authorized to perform the function listed in column 3. This figure represents the active time required to perform that maintenance function at the indicated category of maintenance. If the number or complexity of the tasks within the listed maintenance function vary at different maintenance categories, appropriate "worktime" figures will be shown for each category. The number of man-hours specified by the "worktime" figure represents the average time required to restore an item (assembly, subassembly, component, module, end item or system) to a serviceable condition under typical field operating conditions. This time includes preparation time, troubleshooting time and quality assurance/quality control time in addition to the time required to perform the specific tasks identified for the maintenance functions authorized in the maintenance allocation chart. Subcolumns of column 4 are as follows:

- C - Operator/Crew
- O - Organizational
- F - Direct Support
- H - General Support
- D - Depot

e. Column 5, Tools and Equipment. Column 5 specifies by code, those common tool sets (not individual tools) and special tools, test, and support equipment required to perform the designated function.

B-4. TOOL AND TEST EQUIPMENT REQUIREMENTS (SECTION III).

a. Tool and Test Equipment Reference Code. The numbers in this column coincides with the numbers used in the tools and equipment column of the MAC. The numbers indicate the applicable tool or test equipment for the maintenance functions.

b. Maintenance Category. The codes in this column indicate the maintenance category allocated the tool or test equipment.

c. Nomenclature. This column lists the noun name and nomenclature of the tools and test required to perform the maintenance functions.

d. National/NATO Stock Number. This column lists the National/NATO stock number of the specific tool or test equipment.

e. Tool Number. This column lists the manufacturer's part number of the tool followed by the Federal Supply Code for manufacturers (5 digit) in parenthesis.

SECTION II MAINTENANCE ALLOCATING CHART
FOR
IMPEDANCE BRIDGE ZM-71A/u

(1) GROUP NUMBER	(2) COMPONENT ASSEMBLY	(3) MAINTENANCE FUNCTION	(4) MAINTENANCE CATEGORY					(5) TOOLS AND EQUIPMENT
			C	O	F	H	D	
00	Bridge Impedance ZM-71A/U	Inspect Test Adjust Repair 1	0.1			0.1 0.5 0.5 2.0		1 2-5 2-7 2-10
01	Switch and Drum Assembly (Range and Function) A100 HP Part No: 04260-70020	Inspect Test Repair 2				0.1 1.0 1.0		2 2-10 2-10
02	Circuit Card Assembly A200 (Power supply and 1KHz OSC) HP Part No: 04260-7022	Inspect Test Replace				0.1 1.0 1.0		2 2-10 2
03	Circuit Card Assembly A300 (Reference voltage) HP Part No: 04260-7023	Inspect Test Replace				0.1 1.0 1.0		2 2-10 2
04	Circuit Card Assembly A400 (Detector) HP Part No: 04260-7724	Inspect Test Replace				0.1 1.0 1.0		2 2-10 2
05	Chassis Assembly A500 HP Part No: 04260-7053	Inspect Replace				0.1 2.0		1 2
06	Circuit Card Assembly A600 (Lamp) HP Part No: 04260-7026	Inspect Test Replace				0.1 0.5 0.5		2 2,8 2
07	Resistor Assembly A700 HP Part No: 04260-7029	Inspect Test Repair 3				0.1 1.0 2.0		2 2-10 2-10
0701	Gear Assembly A700A1 HP Part No: 04260-7027	Inspect Test Repair 2				0.1 1.0 2.0		2 2-10 2-10

- 1) By replacement of Circuit Card Assemblies A200 thru A400, Switch assembly A100, and remaining assemblies A500 thru A900.
- 2) By replacement of individual components.
- 3) By replacement of Assembly A700A2 or repair of assembly A700A1.

SECTION II MAINTENANCE ALLOCATION CHART
FOR

TM11-6625 -3077-14

IMPEDANCE BRIDGE ZM-71A/U (Cent)

(1) GROUP NUMBER	(2) COMPONENT ASSEMBLY	(3) MAINTENANCE FUNCTION	(4) MAINTENANCE CATEGORY					(5) TOOLS AND EQUIPMENT
			C	O	F	H	D	
08	Switch Assembly A800 HP Part No: 04260-60010	Inspect				0.1		2
		Test				0.5		2,8
		Replace				0.5		2
09	Dial and Resistor Kit A900 HP Part No: 04260-7031	Inspect				0.1		2
		Test				1.0		2-8
		Replace				1.0		2

- 1) By replacement of Circuit Card Assemblies A200 thru A400, Switch assembly A100, and remaining assemblies A500 thru A900.
- 2) By replacement of individual components.
- 3) By replacement of Assembly A700A2 or repair of assembly A700A1.

TOOL AND TEST EQUIPMENT REQUIREMENTS
 FOR
 Bridge Impedance ZM-71A/U

TOOL OR TEST EQUIPMENT REF. CODE	MAINTENANCE CATEGORY	NOMENCLATURE	NATIONAL NATO STOCK NUMBER	TOOL NUMBER
1	O	Tool Kit TK-101/G	5180-00-064 -5178	
2	H	Tool Kit JTK 17ALL	4931-01-073 -3845	
3	H	Electronic Counter HP 5345A		
4	H	Video Amplifier AM-4380/U HP 5261A	6625-00-269 -4593	
5	O	AC Voltmeter ME-260/U HP 403B	6625-00-965 -1534	
6	H	DC Null Meter HP 413A (see para 2-7)	6625-00-057 -8419	
7	H	Oscillator SG-763/U HP 652A	6625-00-054 -3483	
8	H	Oscilloscope System Tek 5440		
9	H	Voltmeter HP 3490	6625-01-010 -9255	
10	H	Repair Kit MK-772/U	5999-00-757 -7042	
10	H	Transistor Test Set	6625-00-788 -5759	

APPENDIX C

COMPONENTS OF END ITEM AND BASIC ISSUE ITEMS

SECTION I. INTRODUCTION

C-1. SCOPE.

This appendix lists components of the end item and basic issue items for the impedance bridge to help you inventory items required for safe and efficient operation.

C-2. GENERAL.

The Components of End Item and Basic Issue Items List (BII) are divided into the following sections:

a. Section II. Components of End Item. This listing is for information purposes only, and is not authority to requisition replacements. These are part of the end item, but are removed and/or separately packaged for transportation or shipment. As part of the end item, these items must be with the end item whenever it is issued or transferred between property accounts. Illustrations are furnished to assist you in identifying the items.

b. Section III. Basic issue items. These are the minimum essential items required to place the impedance bridge in operation, to operate it, and to perform emergency repairs. Although shipped separately packaged, BII must be with the impedance bridge during operation and whenever it is transferred between property accounts. This manual is your authority to request/requisition replacement BII, based on TOE/MTOE authorization of the end item.

C-3. EXPLANATION OF COLUMNS.

The following provides an explanation of columns found in the tabular listing:

a. Column (1)- Illustration Number (Illus Number). This column indicates the number of the illustration in which the item is shown.

b. Column (2)- National Stock Number. This column indicates the national stock number assigned to the item and will be used for requisitioning purposes.

c. Column (3)- Description. This column indicates the Federal item name and if required, a minimum description to identify and locate the item. The last line for each item indicates the FSCM (in parentheses) followed by the part number.

d. Column (4)- Unit of Measure (U/M). This column indicates the measure used in performing the actual operation/maintenance function. This measure is expressed by a two-character alphabetical abbreviation (e.g., ea, in, pr).

e. Column (5)- Quantity Required (Qty Rqr). This column indicates the quantity of the item authorized to be used with/on the equipment.

SECTION II. COMPONENTS OF END ITEM

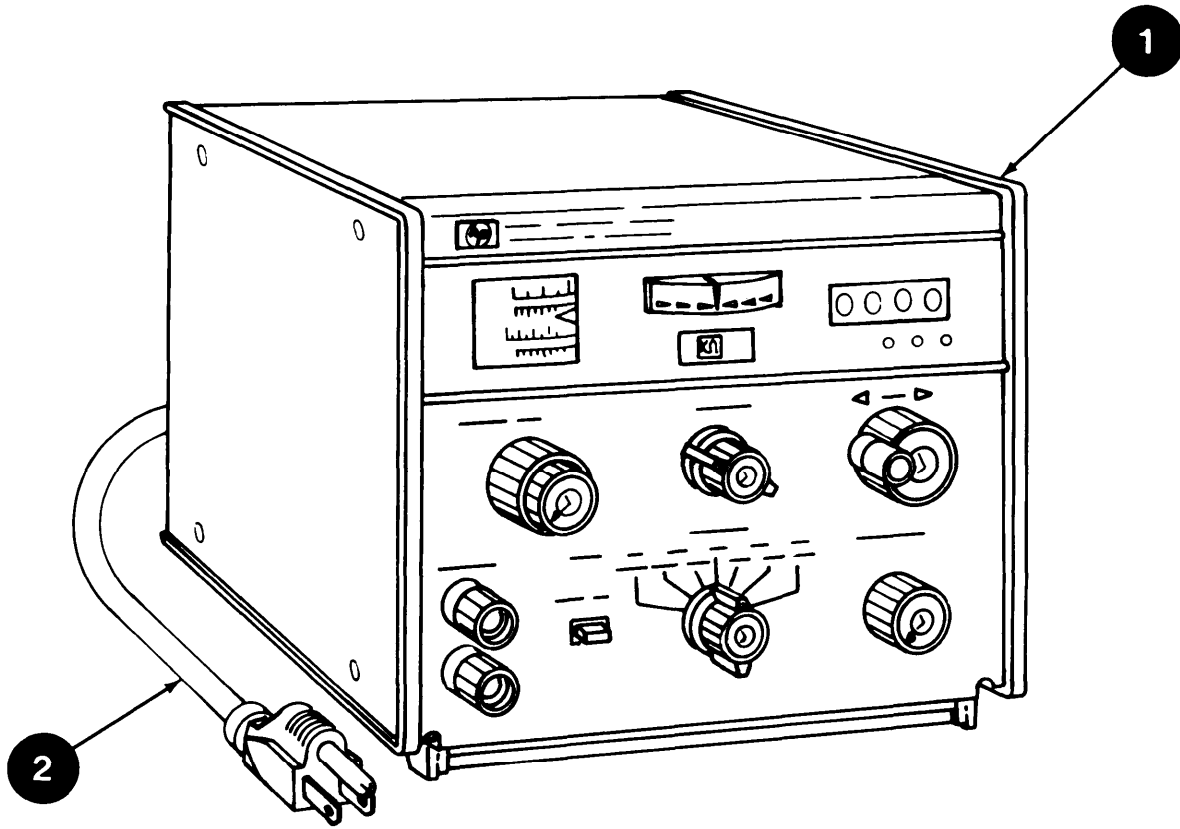

(1) Illus Number	(2) National Stock Number	(3) Description FSCM and Part Number	(4) U/M	(5) Qty Rqr
1	6625-00-236-1536	IMPEDANCE BRIDGE (28480) 4260A	EA	1
2	6150-00-008-5075	CABLE ASSEMBLY, POWER (16428) KH7081	EA	1

SECTION III. BASIC ISSUE ITEMS

(1) Illus Number	(2) National Stock Number	(3) Description FSCM and Part Number	(4) U/M	(5) Qty Rqr
N/A	5920-00-356-2185	FUSE, CARTRIDGE (71400) MDL1-10	EA	1

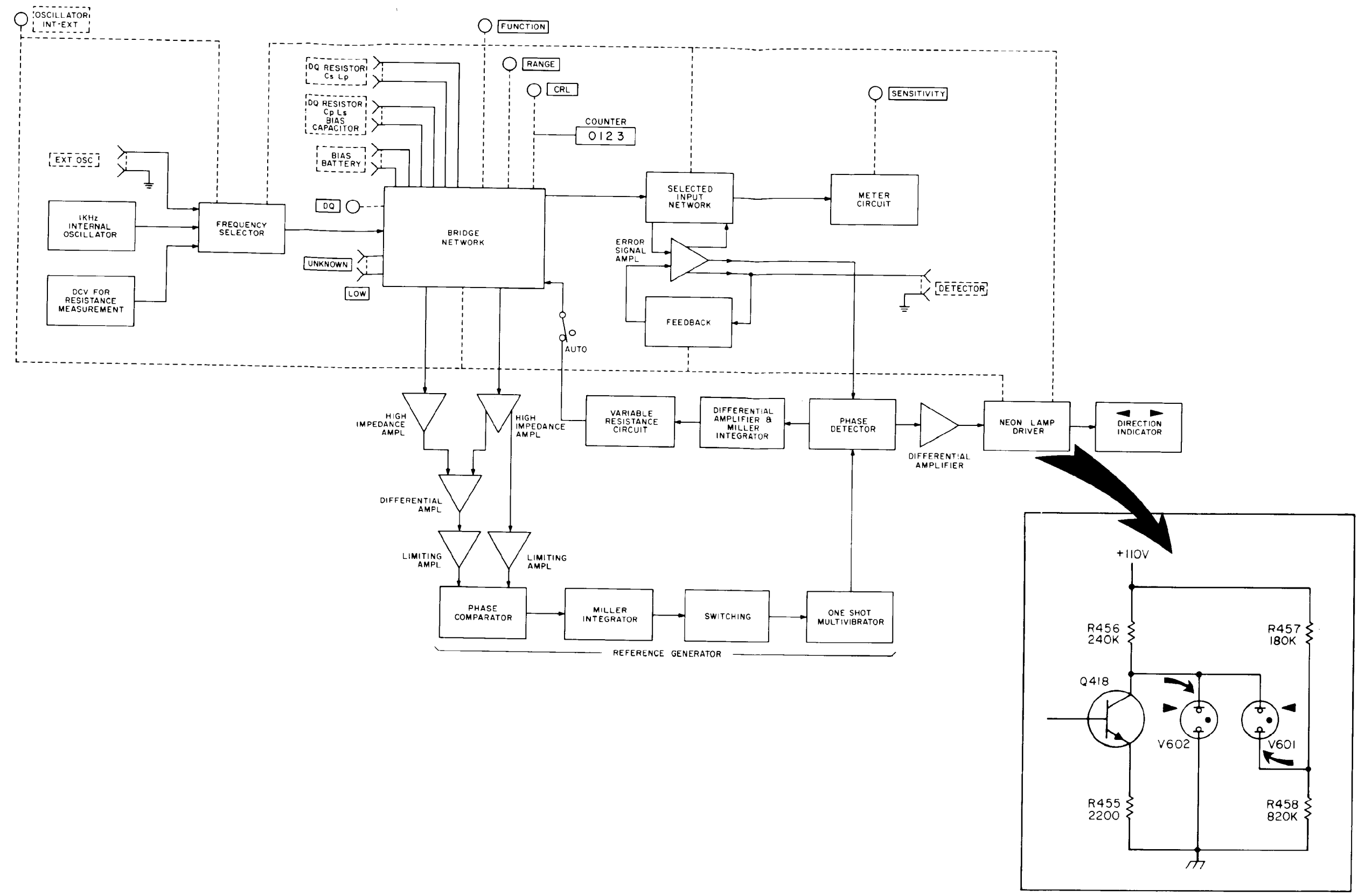

Impedance Bridge Block Diagram

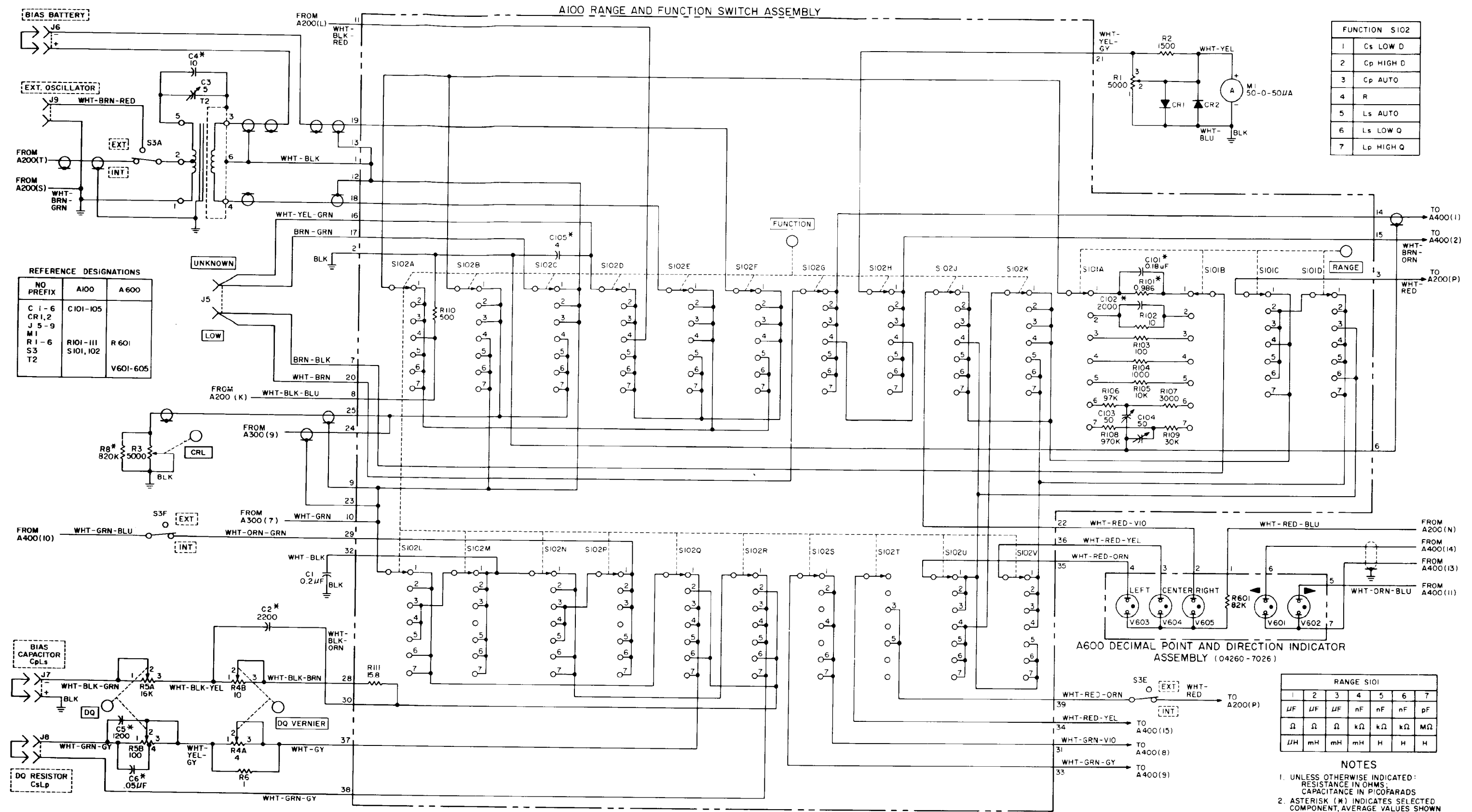

REFERENCE DESIGNATIONS

NO PREFIX	A100	A 600
C 1-6	C101-105	
CR 1,2		
J 5-9		
M 1-6	R101-111	R 601
S 3	S101, 102	
T 2		V601-605

FUNCTION S102

1	Cs LOW D
2	Cp HIGH D
3	Cp AUTO
4	R
5	Ls AUTO
6	Ls LOW Q
7	Lp HIGH Q

RANGE S101

1	2	3	4	5	6	7
μF	μF	μF	nF	nF	nF	pF
Ω	Ω	Ω	kΩ	kΩ	kΩ	MΩ
μH	mH	mH	mH	H	H	H

NOTES
 1. UNLESS OTHERWISE INDICATED: RESISTANCE IN OHMS; CAPACITANCE IN PICO FARADS
 2. ASTERISK (*) INDICATES SELECTED COMPONENT, AVERAGE VALUES SHOWN

Range and Function Switch Schematic Diagram

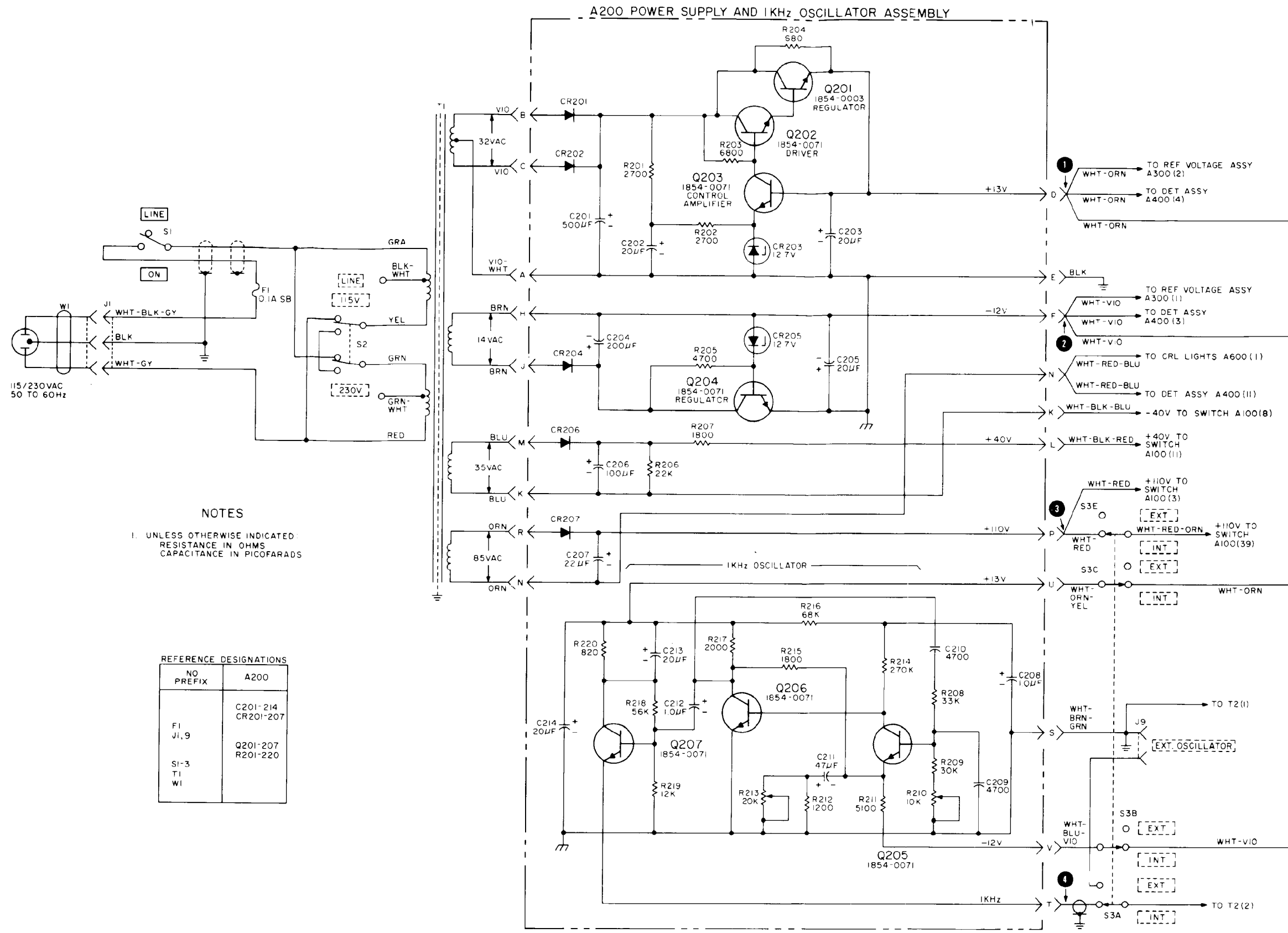

NOTES
 1. UNLESS OTHERWISE INDICATED
 RESISTANCE IN OHMS
 CAPACITANCE IN PICOFARADS

REFERENCE DESIGNATIONS

NO PREFIX	A200
F1	C201-214
J1,9	CR201-207
Q201-207	Q201-207
R201-220	R201-220
SI-3	
T1	
WI	

Power Supply and 1KHz Oscillator Schematic Diagram

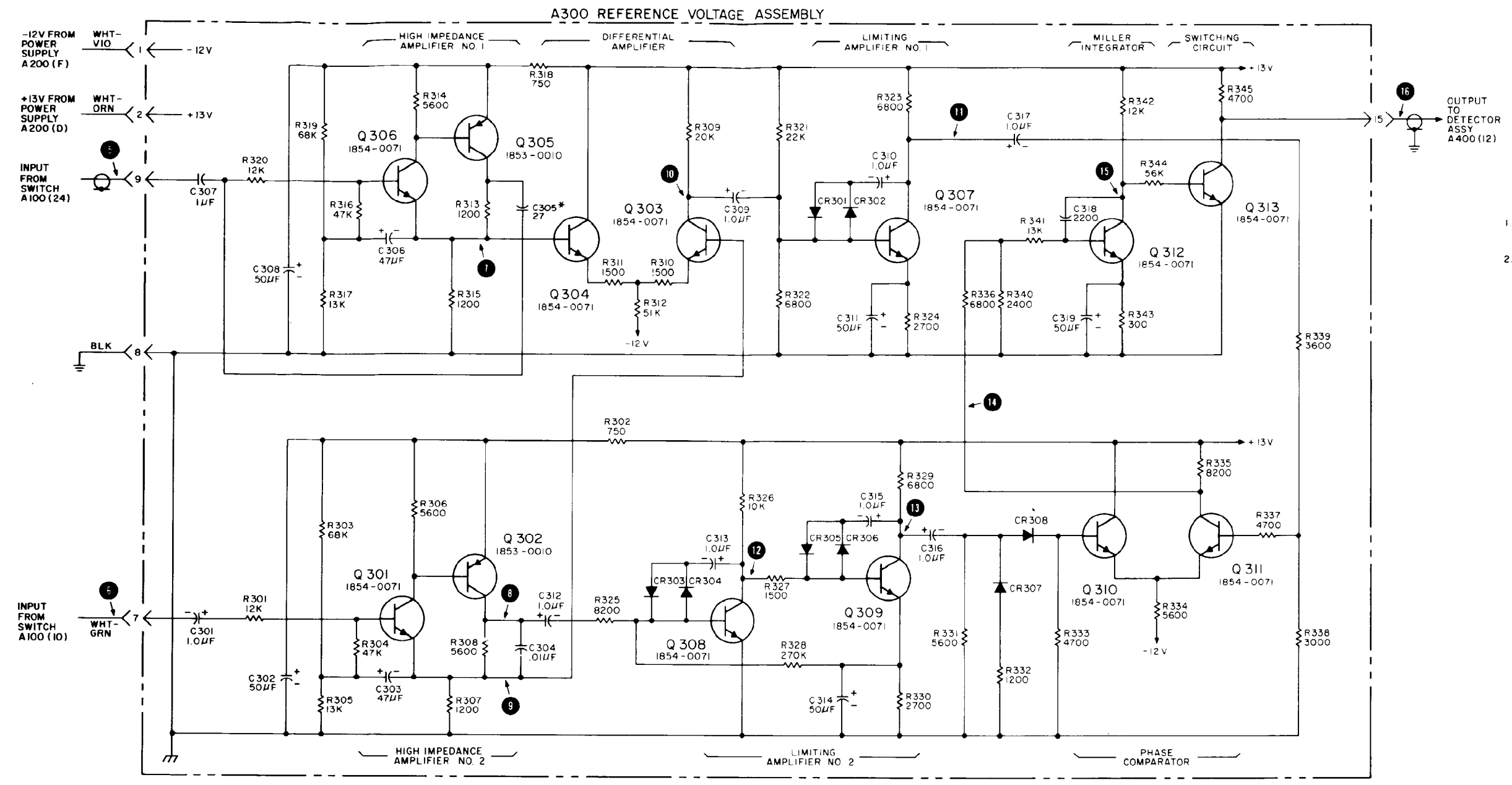

NOTES

1. UNLESS OTHERWISE INDICATED, RESISTANCE IN OHMS, CAPACITANCE IN PICOFARADS
2. ASTERISK (*) INDICATES SELECTED COMPONENT, AVERAGE VALUES SHOWN

REFERENCE DESIGNATIONS

A 300	
C 301 - 319	
CR 301 - 308	
Q 301 - 313	
R 301 - 345	

Reference Voltage Schematic Diagram

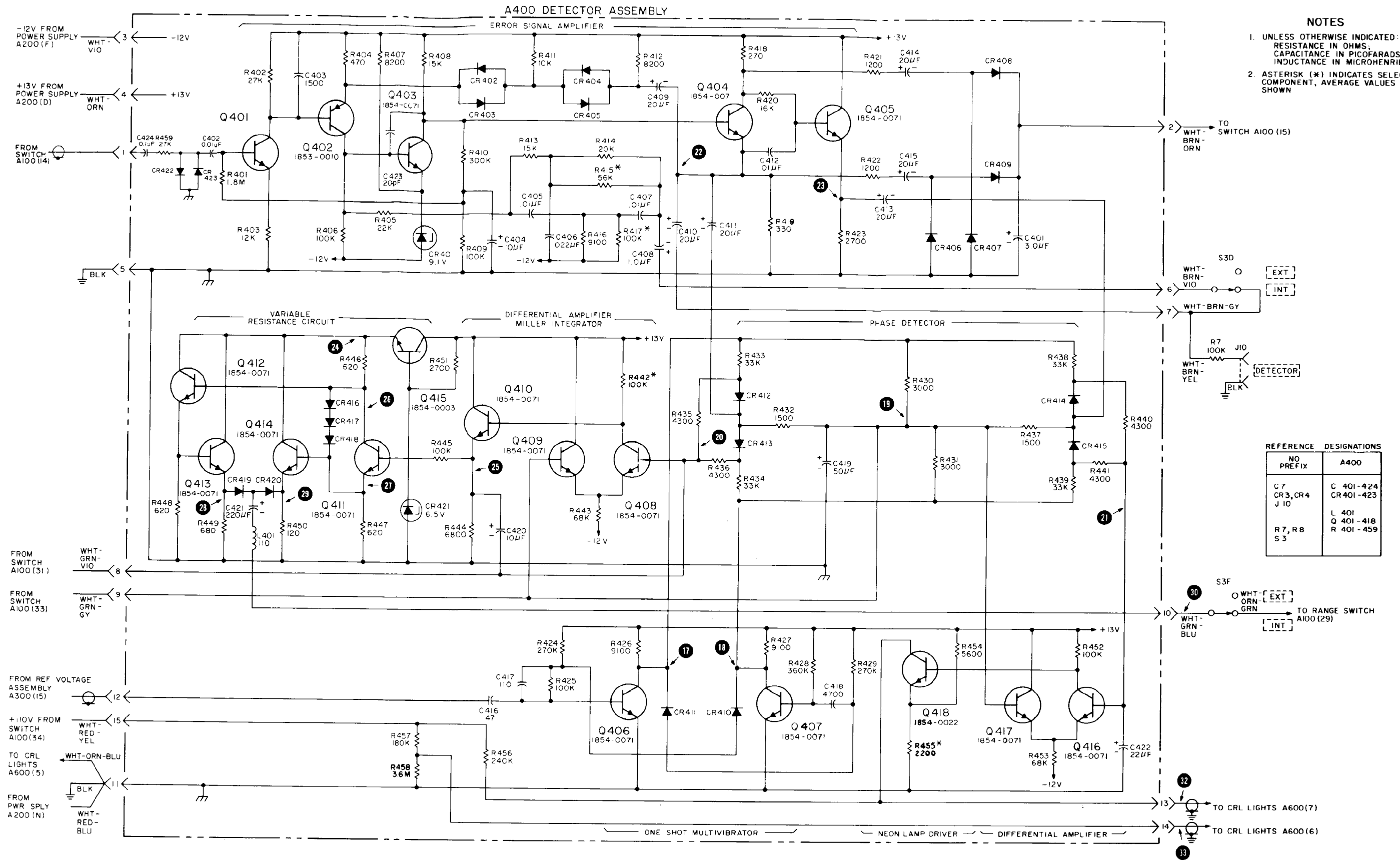

NOTES

1. UNLESS OTHERWISE INDICATED: RESISTANCE IN OHMS; CAPACITANCE IN PICOFARADS; INDUCTANCE IN MICROHENRIES
2. ASTERISK (*) INDICATES SELECTED COMPONENT, AVERAGE VALUES SHOWN

REFERENCE DESIGNATIONS

NO PREFIX	A400
C 7	C 401-424
CR 3, CR 4	CR 401-423
J 10	L 401
R 7, R 8	Q 401-418
S 3	R 401-459

Detector Schematic Diagram

INDEX

SUBJECT	Page
A	
Abbreviations	1-2
C	
Circuit card assembly (A200)	
Adjust	4-41
Remove/install	4-40
Troubleshooting	4-19
Voltage and waveforms	4-22
Circuit card assembly (A300)	
Adjust	4-43
Remove/install	4-42
Troubleshooting	4-19
Voltage and waveforms	4-23
Circuit card assembly (A400)	
Adjust	4-45
Remove/install	4-45
Troubleshooting	4-19
Voltage and waveforms	4-24
Circuit card assembly (A600)	
Adjust	4-50
Remove/install	4-49
Troubleshooting	4-19
Corrosion prevention	4-12
CRL control	
Description	2-4
Remove/install	4-50
Troubleshooting	4-21
D	
Destruction of army material	1-2
DQ control	
Description	2-2
Remove/install	4-50
Troubleshooting	4-19

INDEX (CONTINUED)

SUBJECT	Page
E	
Electrical contacts	
Adjustment	2-10
Cleaning	3-6
F	
Forms and records	1-2
Function switch (A100)	
Adjust	4-37
Description	2-4
Remove/install	4-36
Troubleshooting	4-19
Voltage and waveforms	4-22
Fuse	
Description	2-5
Remove/install	3-6
I	
Impedance bridge	
Decals and instruction plates	2-25
Description	1-4
Operator controls and indicators	2-1
Principles of operation	4-2
Troubleshooting conditions	4-17
K	
Knobs	
Alignment	3-7
Remove/install	3-9
Troubleshooting	3-2
L	
Line voltage selection switch	
Description	2-5
Operation	2-11
Remove/install	4-56
List of illustrations	iii
List of tables	iii

INDEX (CONTINUED)

SUBJECT	Page
M	
Meter	
Description	2-2
Meter zero	2-13
Troubleshooting	4-19
O	
Oscillator switch	
Description	2-6
Remove/install	4-56
P	
Power cable	
Continuity check	3-12
Description	1-5
Power cable input	
Description	2-5
Remove/install	4-56
Power switch	
Description	2-1
Remove/install	4-56
Troubleshooting	4-19
Preventive maintenance	
Operator's	2-7
General support	4-1
R	
Range switch (A100)	
Description	2-3
Remove/install	4-36
Troubleshooting	4-19
Voltage and waveforms	4-22
Reporting of errors	i
S	
Schematic diagrams	4-28

INDEX (CONTINUED)

SUBJECT	Page
S (Continued)	
Sensitivity control	
Description	2-4
Remove/install	4-56
T	
Table of contents	ii
Turn on procedure	2-12
U	
Use of the manual	B
W	
Warranty information	1-2
Wiring diagrams	4-28

RECOMMENDED CHANGES TO EQUIPMENT TECHNICAL PUBLICATIONS



THEN... JOT DOWN THE DOPE ABOUT IT ON THIS FORM. CAREFULLY TEAR IT OUT. FOLD IT AND DROP IT IN THE MAIL!

SOMETHING WRONG WITH THIS PUBLICATION?

FROM (PRINT YOUR UNIT'S COMPLETE ADDRESS)
 Commander
 Stateside Army Depot
 ATTN: AMSTA-US
 Stateside, N.J. 07703

DATE SENT
 10 July 1975

PUBLICATION NUMBER
 TM 11-5840-340-12

PUBLICATION DATE
 23 Jan 74

PUBLICATION TITLE
 Radar Set AN/PRC-76

BE EXACT PIN-POINT WHERE IT IS

PAGE NO	PARA-GRAPH	FIGURE NO	TABLE NO
2-25	2-28		
3-10	3-3		3-1
5-6	5-8		
		FO3	

IN THIS SPACE TELL WHAT IS WRONG AND WHAT SHOULD BE DONE ABOUT IT:

Recommend that the installation antenna alignment procedure be changed throughout to specify a 2° IFF antenna lag rather than 1°.

REASON: Experience has shown that with only a 1° lag, the antenna servo system is too sensitive to wind gusting in excess of 25 knots, and has a tendency to rapidly accelerate and decelerate as it hunts, causing strain to the drive train. Hunting is minimized by adjusting the lag to 2° without degradation of operation.

Item 5, Function column. Change "2 db" to "3db."

REASON: The adjustment procedure for the TRANS POWER FAULT indicator calls for a 3 db (500 watts) adjustment to light the TRANS POWER FAULT indicator.

Add new step f.1 to read, "Replace cover plate removed step e.1, above."

REASON: To replace the cover plate.

Zone C 3. On J1-2, change "+24 VDC to "+5 VDC."

REASON: This is the output line of the 5 VDC power supply. +24 VDC is the input voltage.

PRINTED NAME GRADE OR TITLE AND TELEPHONE NUMBER
 SSG I. M. DeSpirito 999-1776

SIGN HERE

114R 410NG P190R11D1UN1

FILL IN YOUR
UNIT'S ADDRESS

FOLD BACK

DEPARTMENT OF THE ARMY

OFFICIAL BUSINESS
PENALTY FOR PRIVATE USE \$300

POSTAGE AND FEES PAID
DEPARTMENT OF THE ARMY
DOD 314



SAMPLE

Commander
US Army Communications-Electronics Command
and Fort Monmouth
ATTN: DRSEL-ME-MP
Fort Monmouth, New Jersey 07703

TEAR ALONG PERFORATED LINE

RECOMMENDED CHANGES TO EQUIPMENT TECHNICAL PUBLICATIONS



THEN...JOT DOWN THE DOPE ABOUT IT ON THIS FORM. CAREFULLY TEAR IT OUT, FOLD IT AND DROP IT IN THE MAIL.

SOMETHING WRONG WITH THIS PUBLICATION?

FROM: (PRINT YOUR UNIT'S COMPLETE ADDRESS)

DATE SENT

PUBLICATION NUMBER

.TM 11-6625-3077-14

PUBLICATION DATE

PUBLICATION TITLE

Operator's, Org, DS & GS Maint
Manual Impedance Bridge ZM-71A/U

BE EXACT PIN-POINT WHERE IT IS

PAGE NO	PARA GRAPH	FIGURE NO.	TABLE NO

IN THIS SPACE TELL WHAT IS WRONG AND WHAT SHOULD BE DONE ABOUT IT:

TEAR ALONG PERFORATED LINE

PRINTED NAME GRADE OR TITLE AND TELEPHONE NUMBER

SIGN HERE

DA FORM 1 JUL 79 2028-2

PREVIOUS EDITIONS ARE OBSOLETE

P.S.--IF YOUR OUTFIT WANTS TO KNOW ABOUT YOUR RECOMMENDATION MAKE A CARBON COPY OF THIS AND GIVE IT TO YOUR HEADQUARTERS.

FILL IN YOUR
UNIT'S ADDRESS

FOLD BACK

DEPARTMENT OF THE ARMY

OFFICIAL BUSINESS
PENALTY FOR PRIVATE USE \$300

POSTAGE AND FEES PAID
DEPARTMENT OF THE ARMY
DOD 314



TEAR ALONG PERFORATED LINE

Commander
US Army Communications-Electronics Command
and Fort Monmouth
ATTN: DRSEL-ME-MP
Fort Monmouth, New Jersey 07703

RECOMMENDED CHANGES TO EQUIPMENT TECHNICAL PUBLICATIONS



THEN...JOT DOWN THE DOPE ABOUT IT ON THIS FORM. CAREFULLY TEAR IT OUT, FOLD IT AND DROP IT IN THE MAIL.

SOMETHING WRONG WITH THIS PUBLICATION?

FROM: (PRINT YOUR UNIT'S COMPLETE ADDRESS)

DATE SENT

PUBLICATION NUMBER

TM 11-6625-3077-14

PUBLICATION DATE

PUBLICATION TITLE

Operator's, Org, DS & GS Maint Manual Impedance Bridge ZM-71A/U

BE EXACT PIN-POINT WHERE IT IS

PAGE NO.	PARA. GRAPH	FIGURE NO.	TABLE NO.

IN THIS SPACE TELL WHAT IS WRONG AND WHAT SHOULD BE DONE ABOUT IT:

TEAR ALONG PERFORATED LINE

PRINTED NAME GRADE OR TITLE AND TELEPHONE NUMBER

SIGN HERE

DA FORM 1 JUL 79 2028-2

PREVIOUS EDITIONS ARE OBSOLETE

P.S.--IF YOUR OUTFIT WANTS TO KNOW ABOUT YOUR RECOMMENDATION MAKE A CARBON COPY OF THIS AND GIVE IT TO YOUR HEADQUARTERS.

FILL IN YOUR
UNIT'S ADDRESS

FOLD BACK

DEPARTMENT OF THE ARMY

POSTAGE AND FEES PAID
DEPARTMENT OF THE ARMY
DOD 314



OFFICIAL BUSINESS
PENALTY FOR PRIVATE USE \$300

Commander
US Army Communications-Electronics Command
and Fort Monmouth
ATTN: DRSEL-ME-MP
Fort Monmouth, New Jersey 07703

TEAR ALONG PERFORATED LINE

RECOMMENDED CHANGES TO EQUIPMENT TECHNICAL PUBLICATIONS



THEN...JOT DOWN THE DOPE ABOUT IT ON THIS FORM. CAREFULLY TEAR IT OUT, FOLD IT AND DROP IT IN THE MAIL.

SOMETHING WRONG WITH THIS PUBLICATION?

FROM: (PRINT YOUR UNIT'S COMPLETE ADDRESS)

DATE SENT

PUBLICATION NUMBER

TM 11-6625-3077-14

PUBLICATION DATE

PUBLICATION TITLE

Operator's, Org, DS & GS Maint
Manual Impedance Bridge ZM-71A/U

BE EXACT PIN-POINT WHERE IT IS

PAGE NO.	PARA GRAPH	FIGURE NO.	TABLE NO.

IN THIS SPACE TELL WHAT IS WRONG AND WHAT SHOULD BE DONE ABOUT IT:

TEAR ALONG PERFORATED LINE

PRINTED NAME GRADE OR TITLE AND TELEPHONE NUMBER

SIGN HERE

FILL IN YOUR
UNIT'S ADDRESS

FOLD BACK

DEPARTMENT OF THE ARMY

OFFICIAL BUSINESS
PENALTY FOR PRIVATE USE \$300

POSTAGE AND FEES PAID
DEPARTMENT OF THE ARMY
DOD 314



TEAR ALONG PERFORATED LINE

Commander
US Army Communications-Electronics Command
and Fort Monmouth
ATTN: DRSEL-ME-MP
Fort Monmouth, New Jersey 07703

By Order of the Secretary of the Army

Official:

JOHN A. WICKHAM JR.
General, United States Army
Chief of Staff

ROBERT M. JOYCE
Major General, United States Army
The Adjutant General

DISTRIBUTION:

To be distributed in accordance with DA Form 12-36, Direct and General Support Maintenance requirements for MA-1.

